

**Partner Center**

# **Developer Guide**

**Issue**                    1  
**Date**                     2022-12-29



**Copyright © Huawei Technologies Co., Ltd. 2024. All rights reserved.**

No part of this document may be reproduced or transmitted in any form or by any means without prior written consent of Huawei Technologies Co., Ltd.

## **Trademarks and Permissions**



HUAWEI and other Huawei trademarks are trademarks of Huawei Technologies Co., Ltd.

All other trademarks and trade names mentioned in this document are the property of their respective holders.

## **Notice**

The purchased products, services and features are stipulated by the contract made between Huawei and the customer. All or part of the products, services and features described in this document may not be within the purchase scope or the usage scope. Unless otherwise specified in the contract, all statements, information, and recommendations in this document are provided "AS IS" without warranties, guarantees or representations of any kind, either express or implied.

The information in this document is subject to change without notice. Every effort has been made in the preparation of this document to ensure accuracy of the contents, but all statements, information, and recommendations in this document do not constitute a warranty of any kind, express or implied.

# Security Declaration

## Vulnerability

Huawei's regulations on product vulnerability management are subject to the *Vul. Response Process*. For details about this process, visit the following web page:

<https://www.huawei.com/en/psirt/vul-response-process>

For vulnerability information, enterprise customers can visit the following web page:

<https://securitybulletin.huawei.com/enterprise/en/security-advisory>

---

# Contents

---

|   |           |
|---|-----------|
| <b>1 Change History</b>   | <b>1</b>  |
| <b>2 Development Scenario Introduction (Reseller Model)</b>             | <b>2</b>  |
| <b>3 Access Configuration (Optional)</b>                                | <b>5</b>  |
| 3.1 Overview  | 5         |
| 3.2 Basic Configuration   | 5         |
| 3.3 (Optional) Configuring the Redirection URL for the Partner Platform | 10        |
| <b>4 (Optional) Customizing HUAWEI CLOUD Management Console</b>         | <b>13</b> |
| 4.1 Overview  | 13        |
| 4.2 Customizing Logo Display  | 14        |
| 4.3 Customizing the Promotion Page                                      | 15        |
| 4.4 Customizing Huawei Cloud Menu                                       | 15        |
| <b>5 Product Management</b>   | <b>17</b> |
| 5.1 Querying Product Information  | 17        |
| 5.2 Querying the Price of a Product                                     | 20        |
| <b>6 Customer Management</b>  | <b>23</b> |
| 6.1 Registering a Customer  | 23        |
| 6.2 Managing Customers  | 25        |
| <b>7 Transaction Management</b>   | <b>27</b> |
| 7.1 Manage Customer Budgets   | 27        |
| 7.2 Coupon Management   | 29        |
| 7.3 Managing Yearly/Monthly Orders                                      | 29        |
| 7.4 Managing Yearly/Monthly Resources                                   | 32        |
| 7.5 Managing Pay-Per-Use Resources                                      | 34        |
| 7.6 Managing Resource Packages  | 35        |
| <b>8 Cloud Service Resource Management</b>                              | <b>37</b> |
| <b>9 Bill Management</b>  | <b>39</b> |
| 9.1 Managing Customer Resource Usage                                    | 39        |
| 9.2 Partner Bill Management   | 40        |
| 9.2.1 Partner Bills   | 40        |
| 9.2.2 Customer Bills  | 41        |

|   |           |
|---|-----------|
| <b>10 Managing Service Tickets.....</b>           | <b>43</b> |
| <b>11 Appendix.....</b>                           | <b>46</b> |
| 11.1 Creating a Bucket.....                       | 46        |
| 11.2 Obtaining the <b>SP Metadata</b> File.....   | 46        |
| 11.3 Generating the <b>IDP Metadata</b> File..... | 47        |
| 11.4 Sample Code for Parsing the SAMLRequest..... | 49        |
| 11.5 How Do I Check the Partner ID?.....          | 50        |
| 11.6 How Do I Obtain the xaccountType Value?..... | 51        |
| 11.7 Generating a Certificate.....                | 52        |
| 11.8 HUAWEI CLOUD Environment and Address.....    | 56        |

# 1 Change History

| Description  | Released On |
|--|-------------|
| <p>This issue is the second official release. This release incorporates the following changes:</p> <ul style="list-style-type: none"><li>• Modified <a href="#">Development Scenario Introduction (Reseller Model)</a>.</li><li>• Added <a href="#">Coupon Management</a>.</li><li>• Added <a href="#">Managing Pay-Per-Use Resources</a>.</li><li>• Added <a href="#">Managing Resource Packages</a>.</li></ul> | 2024-5-28   |
| <p>This issue is the first official release.</p>   | 2022-12-29  |

# 2 Development Scenario Introduction (Reseller Model)

HUAWEI CLOUD provides E2E operation capabilities for solution partners in scenarios such as product management, customer management, transaction management, cloud service resource management, bill management, service ticket management, and invoice management. Solution partners can build their own sales platforms based on the operation capabilities.

The following figure illustrates the specific scenarios.

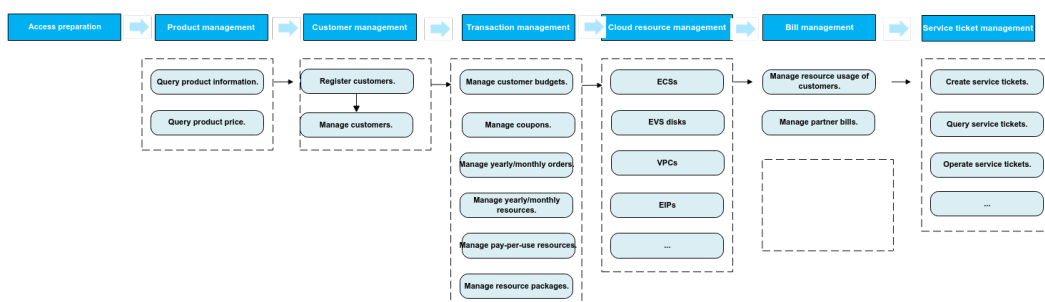

## Product Management

Partners can query the cloud service or resource types, query resources by cloud service type, or query usage types, measurement units, and measurement unit number system on the partner sales platform.

## Customer Management

1. A HUAWEI CLOUD account is created for a customer when the customer creates an account on the partner sales platform, and the customer account on the sales platform is bound to the HUAWEI CLOUD account. In addition, the HUAWEI CLOUD account is bound to the partner account. After registration, the customer can purchase cloud services and manage cloud service resources on HUAWEI CLOUD.
2. Customers can complete real-name authentication on the partner sales platform using business licenses and personal certificates. The HUAWEI

CLOUD reviews the customer authentication information and attachments and returns the result to the partner sales platform. If a customer changes from individual authentication to enterprise authentication, the customer can complete real-name authentication on the partner sales platform. Customers can perform real-name authentication on the partner sales platform using their business licenses or personal certificates. HUAWEI CLOUD reviews the customer authentication information and attachments and sends the result to the partner sales platform. If a customer changes from individual authentication to enterprise authentication, the customer can perform real-name authentication on the partner sales platform.

3. The partner sales platform can also manage the partner customers.

## Coupon Management

On the partner sales platform, partners can view the coupon list.

## Transaction Management

1. A partner can view its customer's budget and set or adjust the budget for its customer on the partner sales platform. The budget is used to control customer's monthly consumption.
2. A partner can view the coupons distributed by themselves.
3. Using the web UI, the customers can switch from the partner sales platform to the cloud service management console on Huawei Cloud through SSO and purchase the cloud services.
4. A partner can view customers' yearly/monthly orders and pay-per-use resources on the sales platform.
5. Partners can view the resource package list, details of resource package usage, and the resource package usage.

## Cloud Service Resource Management

Using the web UI, the customers can switch from the partner sales platform to the cloud service management console on Huawei Cloud through SSO and manage the cloud services.

## Bill Management

1. A partner can query customers' consumption records on the sales platform.
2. A partner can view its monthly bills on the partner sales platform, and settle the bills with HUAWEI CLOUD.
3. A partner can query its monthly expenditures on its sales platform. The expenditures include the detailed consumption records of each customer and the corresponding official website price and partner discount. The partner can perform rating for its customer based on the details and generate the customer bill.

## Service Ticket Management

1. A customer or partner creates a HUAWEI CLOUD service ticket on the partner sales platform. The partner sales platform forwards the service ticket to the



HUAWEI CLOUD after-sales service team. When a customer or partner submits a service ticket, the customer or partner needs to enter the required information based on a template.

2. A customer or partner can query all the HUAWEI CLOUD service tickets or details of a HUAWEI CLOUD service ticket submitted by itself on the partner sales platform.
3. A customer or partner can perform operations on a service ticket submitted by itself, such as urging, deleting, closing, and canceling the service ticket. In addition, they can add messages on the service ticket details page, for example, adding confidential information, providing information required for the customer service handling the service ticket, or asking about the service ticket handling progress.

# 3 Access Configuration (Optional)

## 3.1 Overview

After joining the Cloud Solution Provider Program, you can log in to the Partner Center using the account for joining the program. Configure the basic information, file subscription, contact information, and real-name authentication information on the **Support Center > API Management**.

After you complete the basic configuration, you can continue to configure the redirection address for the partner platform. This step is optional. Access through Web UI requires further configuration.

## 3.2 Basic Configuration

### Procedure

- Step 1** Sign in to Huawei Cloud as a partner. On the top navigation bar, select **Support > Open APIs**.
- Step 2** Click the **Configure** icon in the flowchart to switch to the **Configure** page.

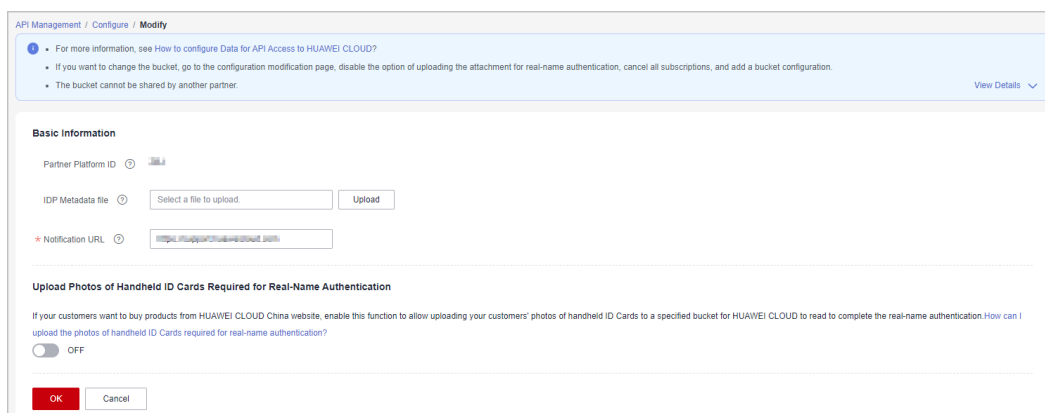

The screenshot shows the 'API Management / Configure / Modify' page. It includes a blue header with a help icon and three bullet points: 'For more information, see How to configure Data for API Access to HUAWEI CLOUD?', 'If you want to change the bucket, go to the configuration modification page, disable the option of uploading the attachment for real-name authentication, cancel all subscriptions, and add a bucket configuration.', and 'The bucket cannot be shared by another partner.' A 'View Details' link is on the right. Below is the 'Basic Information' section with fields for 'Partner Platform ID', 'IDP Metadata file' (with a 'Select a file to upload' button and 'Upload' button), and '\* Notification URL' (with a text input field). The 'Upload Photos of Handheld ID Cards Required for Real-Name Authentication' section has a toggle switch set to 'OFF' and a small explanatory text. At the bottom are 'OK' and 'Cancel' buttons.

- Step 3** Set the parameters based on [Table 3-1](#). After the configuration is complete, click **OK**.

**Table 3-1** Parameter descriptions

| Parameter   | Description   |
|---|---|
| <b>Basic Information</b>  |   |
| IDP metadata file (enterprise identity provider metadata file)  | <p>Indicates the <b>IDP Metadata</b> file in .xml format generated by the partner sales platform according to the SAML protocol standards.</p> <p>The file must be in the .xml format, and its size cannot exceed 2 MB.</p> <p>For details about how to generate the IDP metadata file, see <a href="#">Generating the IDP Metadata File</a>.</p> |
| Notification URL  | <p>Indicates the callback address provided by the partner sales platform for receiving the association result. Using an address in HTTPS is recommended. For details, see <a href="#">Association Result Notification API</a>.</p>  |
| <b>Upload Photos of Handheld ID Cards Required for Real-Name Authentication</b>   |   |
| <p>If a partner's customers buy products from HUAWEI CLOUD Chinese mainland website and want to perform real-name authentication, customers need to upload pictures of the certificates for HUAWEI CLOUD to read to complete the real-name authentication. For details about how to upload the attachment for real-name authentication, see <a href="#">How Do I Upload the Attachment for Real-Name Authentication?</a></p>  |   |
| <b>File Subscription</b>  |   |
| <ul style="list-style-type: none"> <li>• After you subscribe to the partner bill (customer consumption details), you can rate your customers, and your sales platform will generate the customer bills based on this bill and then you can perform reconciliation with HUAWEI CLOUD.</li> <li>• You can subscribe to customer resource usage details and view resource usage details of all your customers or a specified customer on the partner sales platform. Customers can view their own resource usage details on the partner sales platform.</li> </ul> |   |

**Step 4** Specify bucket information if you have enabled the real-name authentication or file subscription.

**Table 3-2** Bucket parameters

| Parameter   | Description   |
|-------------|---|
| AK          | Indicates the Access Key ID (AK) which is used when the partner sales platform accesses the OBS client or SDK. For details about how to obtain the AK, see <a href="#">Obtaining an AK/SK</a> .     |
| SK          | Indicates the Secret Access Key (SK) which is used when the partner sales platform accesses the OBS client or SDK. For details about how to obtain the SK, see <a href="#">Obtaining an AK/SK</a> . |
| Bucket Name | Indicates the name of the bucket created by the partner. Only OBS buckets purchased on Huawei Cloud in the Hong Kong region can be used.  |

----End

## Association Result Notification API

If the partner sales platform connects to HUAWEI CLOUD by switching to the HUAWEI CLOUD portal, the partner needs to provide a callback API for HUAWEI CLOUD sending the association result to the partner. An HTTPS URL is recommended.

The partner needs to comply with the following requirements when defining and developing this API.

1. URL  
POST <https://www.example.com/bind>
2. Request Parameters  
The request parameters are in Form Data format.

**Table 3-3** Parameter information

| Parameter   | Description   | Example  |
|-------------|---|--|
| bindRequest | Indicates the message body of the association result (JSON format). The message is coded using BASE64. For details about the parameters in the JSON message body, see <a href="#">Table 3-4</a> .   | EYJKB21HAW5OYW1LIJO<br>IEW9UZ3POASISIMRVB<br>WFPBKLKIJOWIEW9UZ3PO<br>AWLKIIWIEFVZZXJJZ-<br>CI6INLVBMD6AGL4IIWIY<br>MLUZEFJDGLVBII6MX0%<br>3D           |
| SigAlg      | Indicates the signature algorithm. SHA256 is used for signature by default.<br><a href="http://www.w3.org/2001/04/xml-dsig-more#rsa-sha256">HTTP://WWW.W3.ORG/2001/04/<br/>XMLDSIG-MORE#RSA-SHA256</a>  | HTTP%3A%2F<br>%2FWWW.W3.ORG<br>%2F2001%2F04%2FXML<br>DSIG-MORE%23RSA-<br>SHA256  |
| Signature   | Indicates the signature. The signature is used to verify the initiator of a request.<br>When HUAWEI CLOUD initiates a request, it uses the private key and the <b>bindRequest</b> value in the request to obtain the signature. When receiving the request, the receiver verifies the signature using the public key provided by HUAWEI CLOUD (the value in the <b>&lt;ds:X509Certificate&gt;&lt;/ds:X509Certificate&gt;</b> tag in the <b>SP Metadata</b> file).<br>If the signature verification succeeds, the request is sent by HUAWEI CLOUD, and the follow-up operations can be performed. Otherwise, the request is invalid. | SWCFTCP4NKMU<br>%2BOBH1FCSXFY0DL31<br>BGNH4EXUGTQY<br>%2BSPLXC%2B94NXSS<br>%2FRHPWYE9TXVNVSP<br>R6XRWBZLVHTBDRGLGC<br>0OPTTCFYD4D3%2F6PM<br>ESNG5C4BPT |

**Table 3-4** Parameters in the **bindRequest** JSON message

| Parameter  | Parameter Type | Description   |
|------------|----------------|---|
| xUserId    | String         | Indicates the user ID of the partner's customer on the partner sales platform.  |
| xAccountId | String         | Indicates the ID of the customer account created on the partner sales platform. An account ID must be unique and is better to be consistent with the <b>domainName</b> .                                  |
| domainName | String         | Indicates the HUAWEI CLOUD account of the partner's customer. This account will be used when the API is invoked.  |
| domainId   | String         | Indicates the HUAWEI CLOUD account ID of the partner's customer. This ID will be used when the API is invoked.  |
| userName   | String         | Indicates the HUAWEI CLOUD username of the partner's customer.  |
| userId     | String         | Indicates the HUAWEI CLOUD user ID of the partner's customer.   |
| exporetime | String         | Indicates the time when a request expires. The value is in UTC format.<br>Example: 2017-07-31T07:40:14.004Z   |
| bindAction | String         | Indicates the association result. <ul style="list-style-type: none"> <li>● <b>0</b>: indicates that the association is successful.</li> <li>● <b>1</b>: indicates that the association failed.</li> </ul> |

 **NOTE**

**Table 3-4** lists the account name, username, account ID, and user ID because HUAWEI CLOUD IAM has account and username concepts. For details about the two concepts, see "Account" and "IAM User" in [Identity Management](#).

## Follow-Up Procedure

If you find any parameters are incorrectly configured, you can modify the configuration.

**Step 1** On the top navigation bar, select **Support > Open APIs**.

**Step 2** Click the access configuration icon or **View or Modify API Configuration** under the icon.

The access configuration page is displayed.

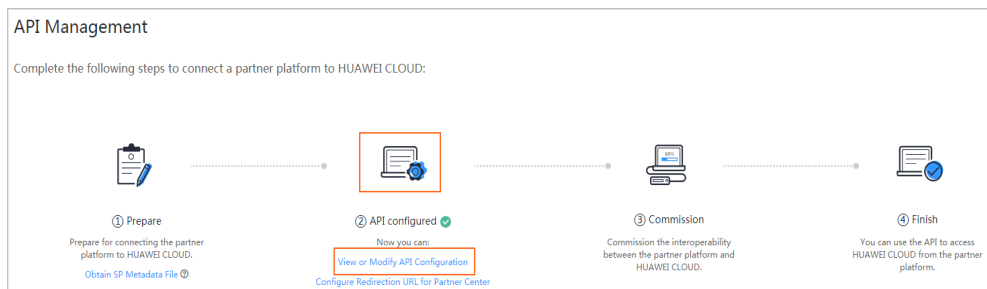

**Step 3** Click **Modify** and modify the configuration as required.

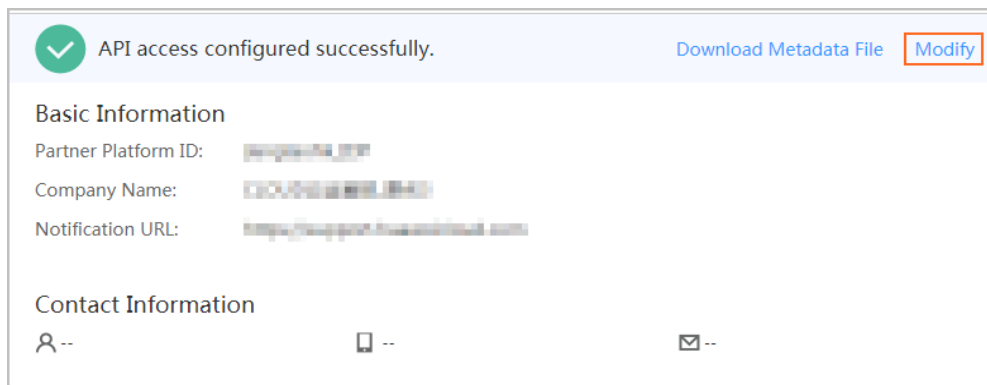

If the **IDP Metadata** file is incorrectly configured, click **Download Metadata File** to download the file to the local, modify and save it, click **Modify**, and then upload the file again.

----End

### 3.3 (Optional) Configuring the Redirection URL for the Partner Platform

After you configure the access parameters, you can configure the redirection URL for Partner Center on the **API Management** page. Then, customers can return to the partner sales platform after they pay the bills.

**View the order details after the payment is complete.**

After customers pay the order, they can click **View order** on the displayed page to switch to the order details page. If the partner has configured the redirection URL, customers can click **View order** to return to the partner sales platform to view the order details.

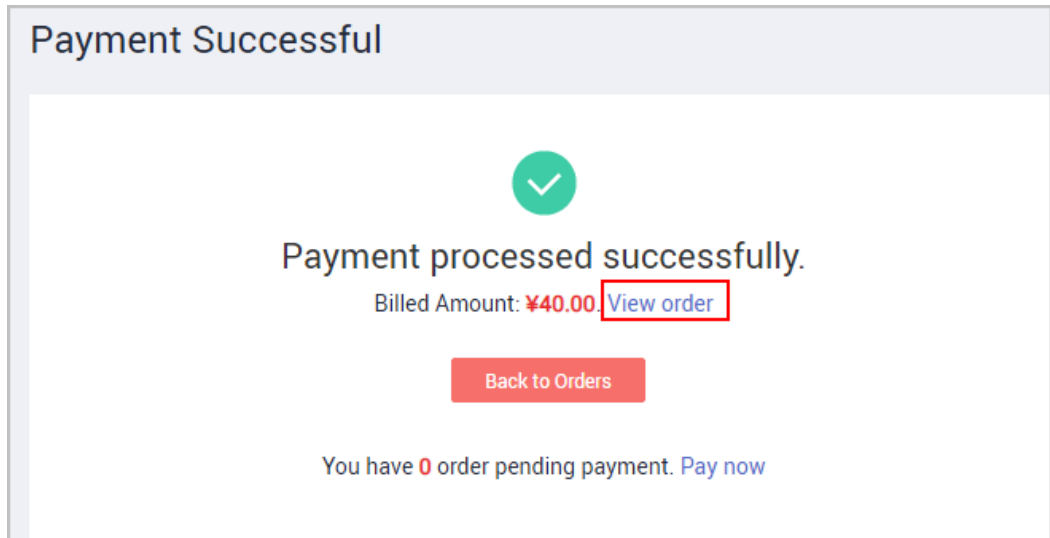

**Step 1** On the top navigation bar, select **Support > Open APIs**.

**Step 2** Click **Configure Redirection URL for Partner Center** under **Configure**.

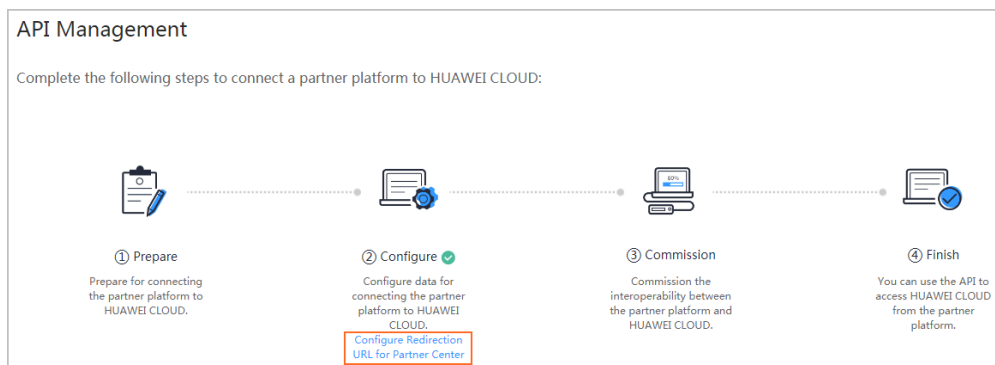

**Step 3** Configure the redirection URL and then click **OK**.

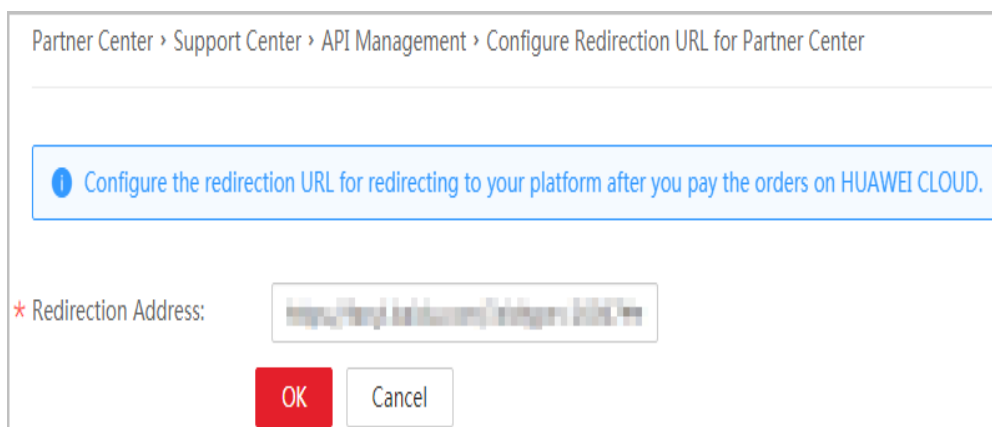

If **Redirection Address** is incorrect, you can switch to the **Configure Redirection URL for Partner Center** page and click **Modify** in the upper right corner of page and modify the configuration.



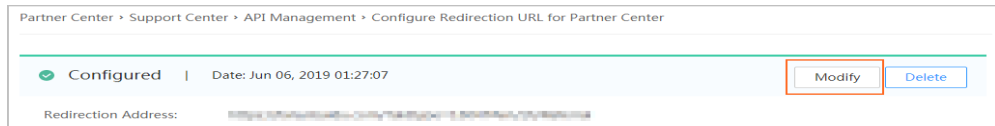

----End

# 4 (Optional) Customizing HUAWEI CLOUD Management Console

## 4.1 Overview

After you configure the [access setting](#), you can customize the HUAWEI CLOUD console on the **Support Center > API Management** page. Specifically, you can define the brand display, promotion menu, and HUAWEI CLOUD menu of the console. After the customization is complete, when a customer of the partner switches from the partner platform to the HUAWEI CLOUD console, the customized HUAWEI CLOUD console will be displayed.

After the partner submits the customization information, the HUAWEI CLOUD operations administrator will complete the review within three working days. After the application is approved, the customization is complete.

- Step 1** Sign in to Huawei Cloud as a partner. On the top navigation bar, select **Support > Open APIs**.
- Step 2** Click **Customize HUAWEI CLOUD Console** under the access configuration icon in the flowchart. The **Customize Console** page is displayed.

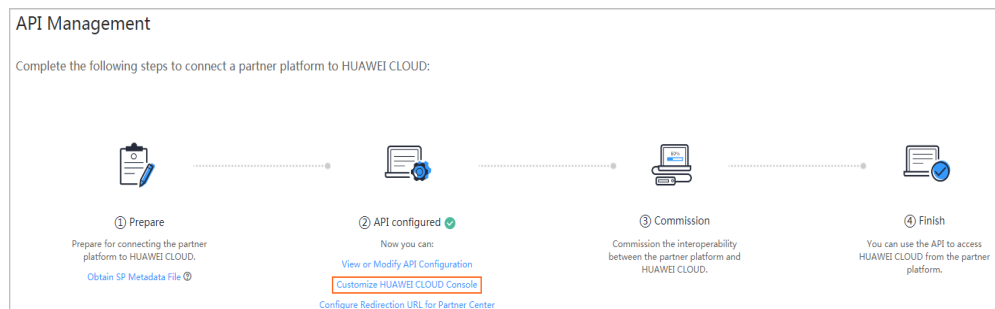

- Step 3** On the **Customize Console** page, you can click the **Brand, Promotion, Menu, and User Information** tabs as required and customize the configuration to meet your specific requirements. The unconfigured items will be the same as those on HUAWEI CLOUD.

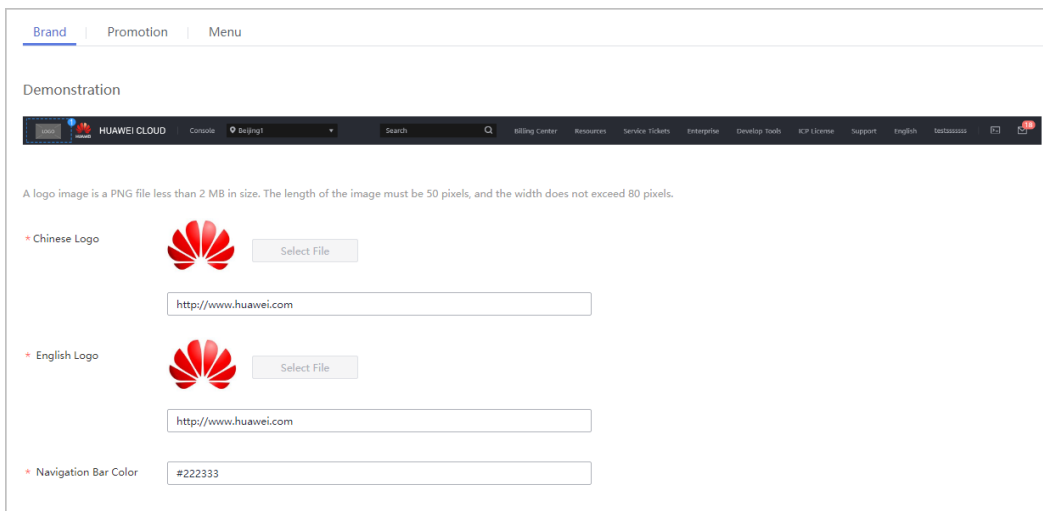

**Step 4** After you confirm the configuration, click **Submit** in the upper right corner. The HUAWEI CLOUD operations administrator will complete the review within three working days.

----End

The following describes the customization on each tab.

## 4.2 Customizing Logo Display

You can upload your enterprise logo and set the HUAWEI CLOUD console to display both the Huawei and your logos.

**Step 1** On the **Customize Console** page, click the **Brand** tab.

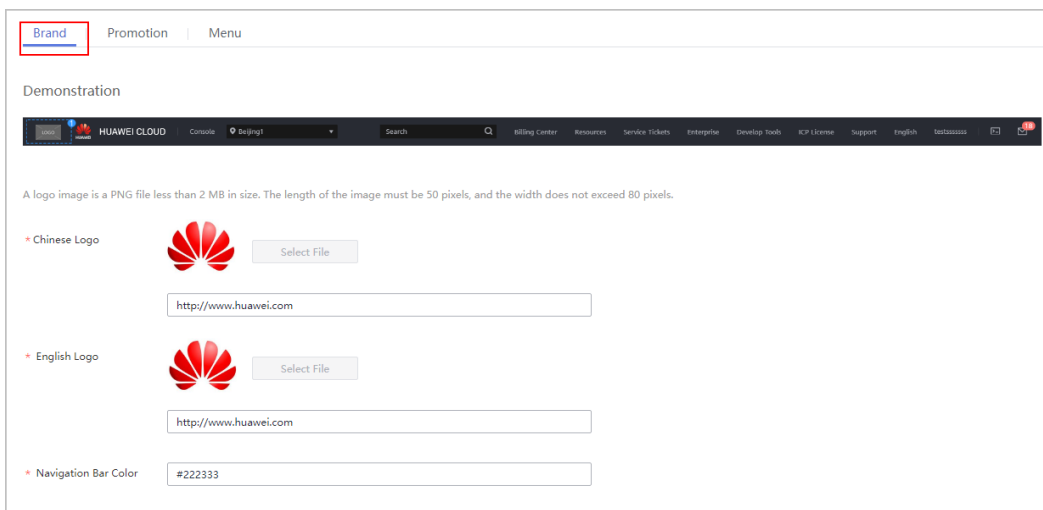

**Step 2** Click **Select File** and upload your Chinese and English logos. If they are the same, you can upload the same picture. Then, click **Submit**.

**Step 3** Configure the redirection URL for each logo.

- Step 4** Enter the RGB color code in the **Navigation Bar Color** text box.  
----End

## 4.3 Customizing the Promotion Page

You can configure the promotion page on the HUAWEI CLOUD console to display your promotions and advertisements.

- Step 1** On the **Customize Console** page, click the **Promotion** tab.

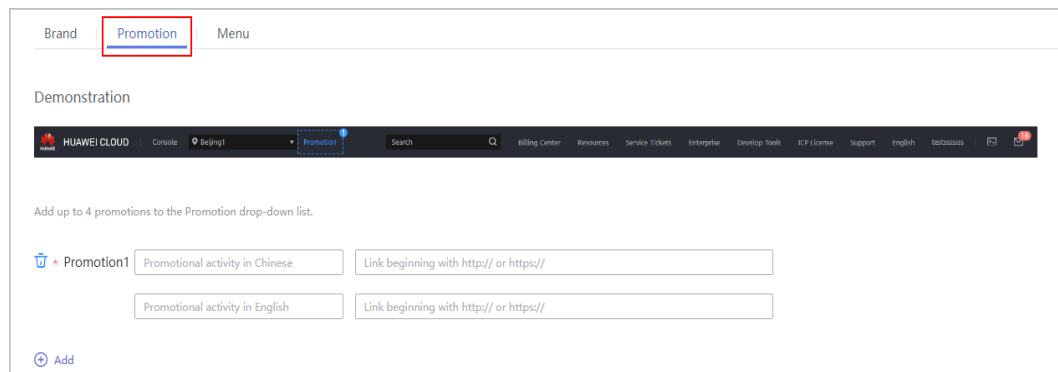

- Step 2** Click **Add**. In the **Promotion** pane, enter the name and link of the promotion.  
----End

## 4.4 Customizing Huawei Cloud Menu

You can customize menus displayed on the HUAWEI CLOUD console, including the information menu, resource drop-down list, username drop-down list, and customized menu.

- Step 1** On the **Customize Console** page, click the **Menu** tab.

The screenshot shows the 'Menu' configuration page in the Huawei Cloud Management Console. The top navigation bar includes 'Brand', 'Promotion', and 'Menu'. Below the navigation bar, there are three sections for configuring the menu:

- 1. Navigation Bar Menu**: Specify 5 items at most in the menu. The Resources option is mandatory, and you can customize one item.
  - Billing Center
  - Resources
  - Service Tickets
  - Enterprises
  - ICP License
- 2. Resources Drop-Down List**: My Resources, My Quotas, and Open Beta Tests are mandatory.
  - My Resources
  - My Marketplace
  - My Quota
  - Open Beta Tests
- 3. Username Drop-Down List**: Specify 9 items at most in the username drop-down list.
  - Basic Information
  - Security Settings
  - My Credential
  - Identity and Access Management
  - Seller Center
  - Partner Center
  - Switch Role
  - Tag Management

At the bottom, there is a 'Menu' section with two items:

- Menu1**: Promotional activity in Chinese (Link beginning with https:// or https://)
- Promotional activity in English (Link beginning with https:// or https://)

**Step 2** Configure menus for each menu pane.

- Select the menus to be displayed on the console.
- Click **Add** to add a menu and configure the menu name and link.

----End

# 5 Product Management

## 5.1 Querying Product Information

### Service Object

Partners

### Scenario Description

On the sales platform, partners can:

- Query the cloud service or resource type.
- Query resources by cloud service type.
- Query the usage type, measurement unit, and measurement unit number system.

### Related APIs

| API                                      | API Definition  |
|--|---|
| Querying cloud service types             | <a href="https://support.huaweicloud.com/eu/api-bpconsole/en-us_topic_0000001256679455.html">https://support.huaweicloud.com/eu/api-bpconsole/en-us_topic_0000001256679455.html</a> |
| Querying resource types                  | <a href="https://support.huaweicloud.com/eu/api-bpconsole/en-us_topic_0000001256519451.html">https://support.huaweicloud.com/eu/api-bpconsole/en-us_topic_0000001256519451.html</a> |
| Querying resources by cloud service type | <a href="https://support.huaweicloud.com/eu/api-bpconsole/qct_00003.html">https://support.huaweicloud.com/eu/api-bpconsole/qct_00003.html</a>                                       |
| Querying usage types                     | <a href="https://support.huaweicloud.com/eu/api-bpconsole/qct_00004.html">https://support.huaweicloud.com/eu/api-bpconsole/qct_00004.html</a>                                       |
| Querying measurement units               | <a href="https://support.huaweicloud.com/eu/api-bpconsole/qct_00006.html">https://support.huaweicloud.com/eu/api-bpconsole/qct_00006.html</a>                                       |

| API   | API Definition  |
|---|---|
| Querying the measurement unit number system | <a href="https://support.huaweicloud.com/eu/api-bpconsole/qct_00007.html">https://support.huaweicloud.com/eu/api-bpconsole/qct_00007.html</a> |

### API Invoking Process

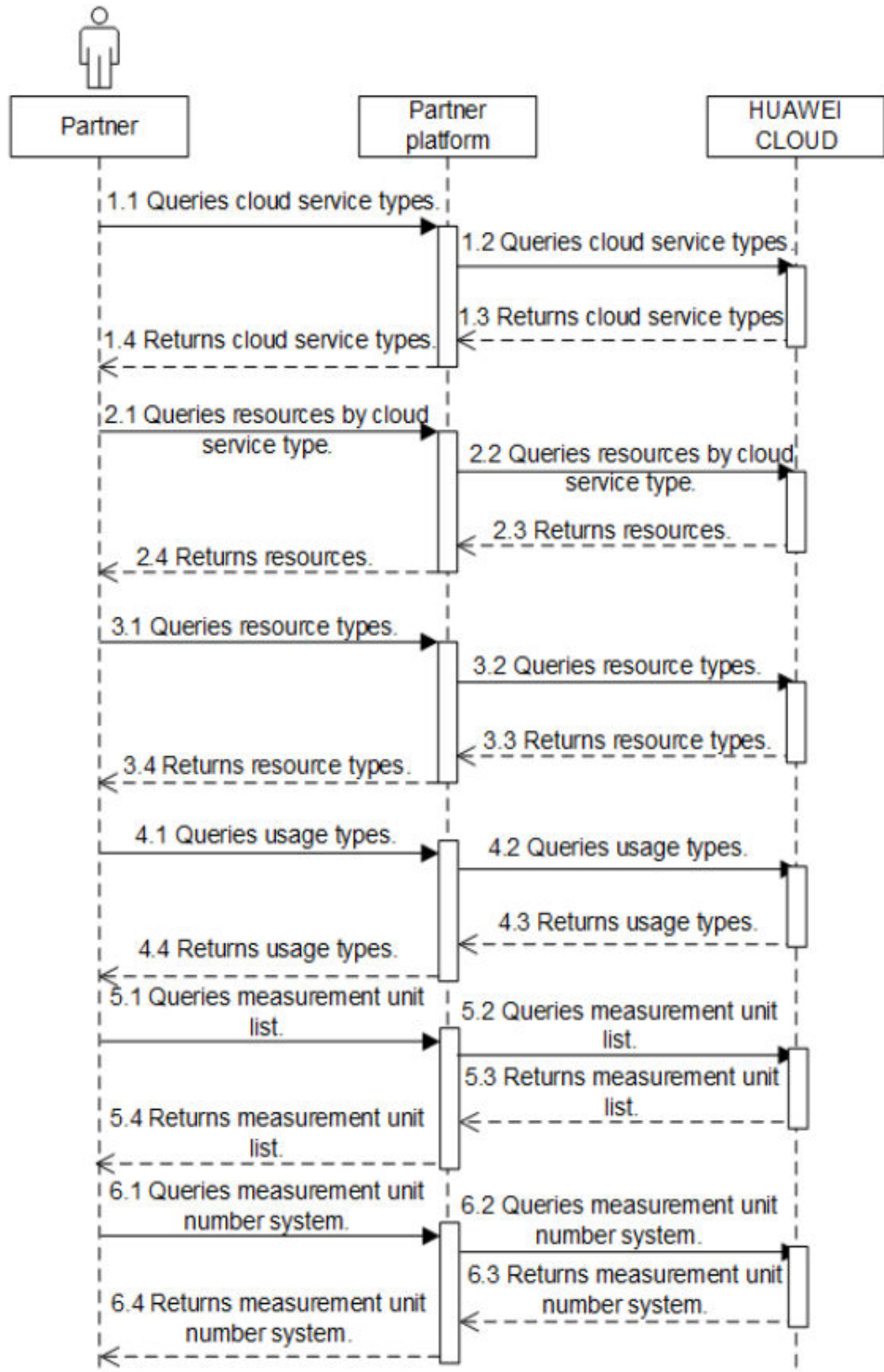



## 5.2 Querying the Price of a Product

### Service Object

Partner's customers

### Scenario Description

Customers can view introductions to cloud services, such as ECS, EVS, VPC, and EIP, and purchase the cloud services. Two solutions are available for the partner sales platform to support their customers purchase cloud services:

Solution 1: Using the web UI, the customers can switch from the partner sales platform to the cloud service management console on HUAWEI CLOUD through SSO and purchase the cloud services.

Solution 2: Using the native cloud service API of HUAWEI CLOUD, the customers can purchase cloud services on the partner sales platform.

Solution 1 is recommended for partners with limited development capabilities or time.

### Related APIs

| API  | API Definition  |
|--|---|
| Querying the price of a pay-per-use product                          | <a href="https://support.huaweicloud.com/eu/api-bpconsole/bcloud_01001.html">https://support.huaweicloud.com/eu/api-bpconsole/bcloud_01001.html</a> |
| Querying the price of a yearly/monthly product                       | <a href="https://support.huaweicloud.com/eu/api-bpconsole/bcloud_01002.html">https://support.huaweicloud.com/eu/api-bpconsole/bcloud_01002.html</a> |
| Switching from the partner sales platform to the HUAWEI CLOUD portal | None  |

### API Invoking Process

Through native APIs of HUAWEI CLOUD services

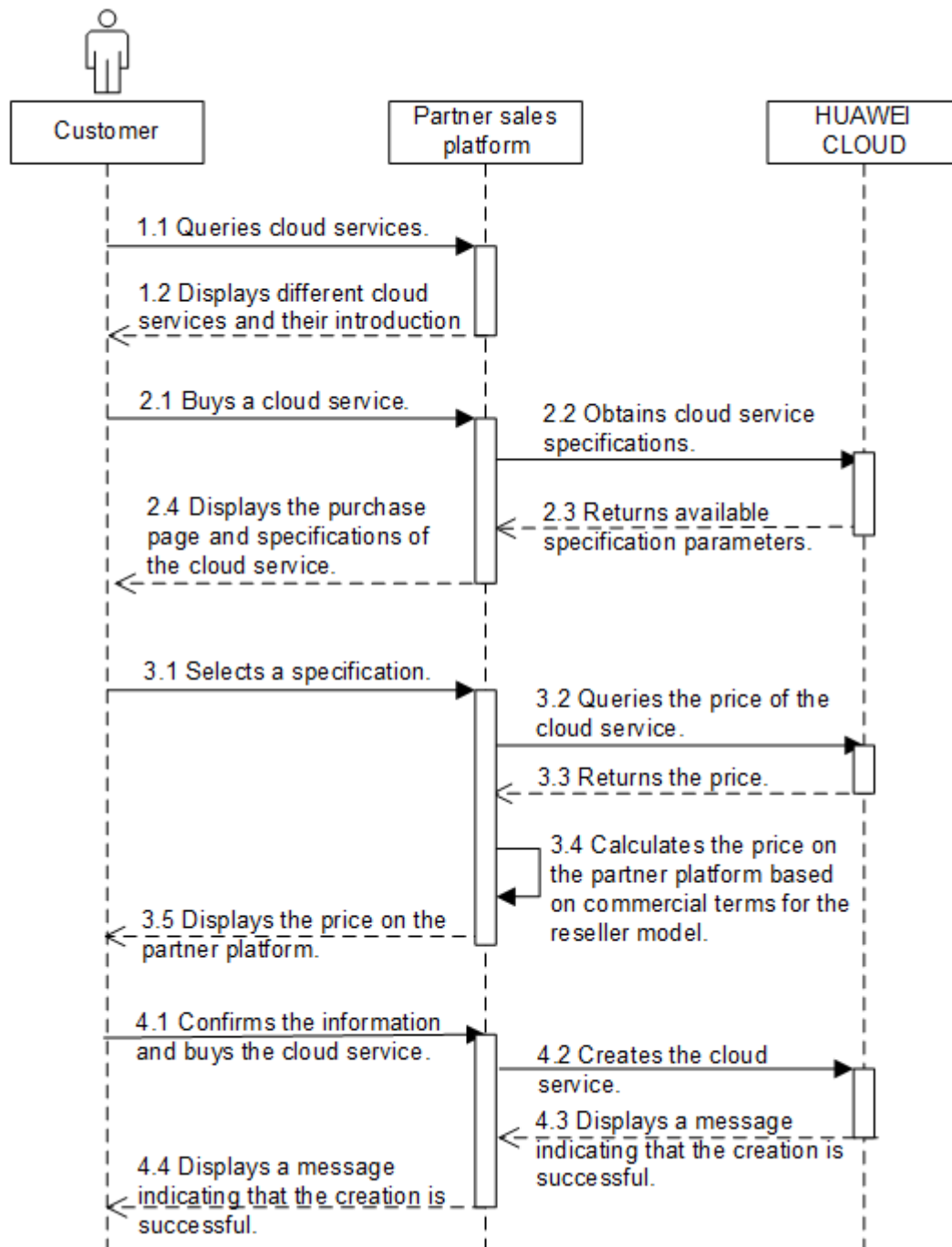

## Development Suggestions

1. For the solution through web UI integration, it is recommended to display the HUAWEI CLOUD service console in a new tab or page for a customer when the customer clicks the purchase button on the partner sales platform page. The links can be specified based on the HUAWEI CLOUD cloud service console links.
2. Partners can configure the redirection URL on the **Support Center > API Management** page to allow customers to return to the partner platform after

completing the order payment. For details, see [\(Optional\) Configuring the Redirection URL for the Partner Platform](#).

# 6 Customer Management

---

## 6.1 Registering a Customer

### Service Object

Partner's customers

### Scenario Description

A HUAWEI CLOUD account is created for a customer when the customer creates an account on the partner sales platform, and the customer account on the sales platform is bound to the HUAWEI CLOUD account. In addition, the HUAWEI CLOUD account is bound to the partner account, so the customer is associated to the partner.

### Related APIs

| API   | API Definition  |
|---|---|
| Verifying customer registration information | <a href="https://support.huaweicloud.com/eu/api-bpconsole/mc_00023.html">https://support.huaweicloud.com/eu/api-bpconsole/mc_00023.html</a> |
| Sending a verification code                 | <a href="https://support.huaweicloud.com/eu/api-bpconsole/mc_00024.html">https://support.huaweicloud.com/eu/api-bpconsole/mc_00024.html</a> |
| Creating a customer                         | <a href="https://support.huaweicloud.com/eu/api-bpconsole/mc_00016.html">https://support.huaweicloud.com/eu/api-bpconsole/mc_00016.html</a> |

### API Invoking Process

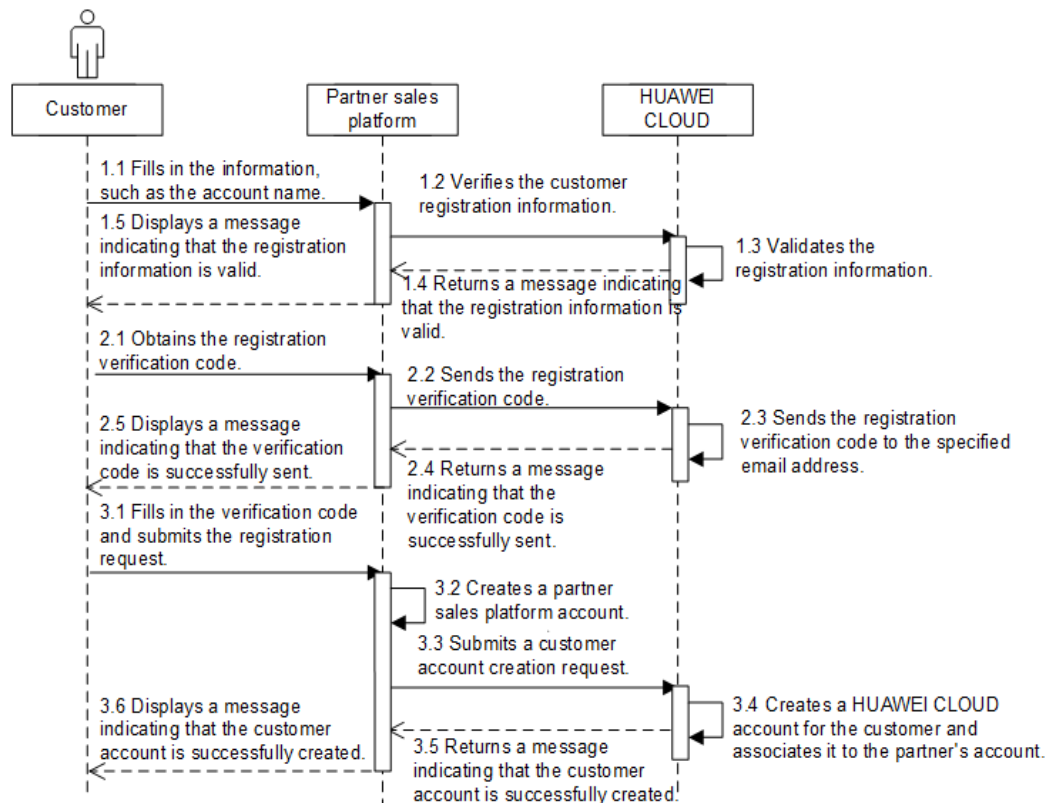

## Development Suggestions

- The account name and email address must be verified valid for Huawei Cloud by invoking the API for verifying the customer registration information. If the email address is not specified, the customer will not receive any notifications such as verification code and resource expiration notifications, and does not need to enter the verification code when creating a Huawei Cloud account for the customer.
- The Huawei Cloud account name can be the same as the account name on the partner sales platform. If the account name is not specified, Huawei Cloud will automatically generate an account name.
- The **xAccountId** field is used to associate the partner sales platform account with the HUAWEI CLOUD account, and is globally unique. When a customer switches to the HUAWEI CLOUD portal from the partner sales platform, this field is used to identify the customer. The value must be the same as that entered when the customer account is created.
- The value of **password** is the password of the HUAWEI CLOUD account. It is optional. If the value is not specified, HUAWEI CLOUD will automatically generate one.
- When the API for creating a customer is invoked, HUAWEI CLOUD will synchronously create a HUAWEI CLOUD customer account and send the customer ID and account name to the partner platform. Then, HUAWEI CLOUD associates the customer with the partner asynchronously. To query the result of associating the partner and customer, see [Querying Customers](#).
- If a customer has created an account on the partner sales platform and does not have a HUAWEI CLOUD account, the customer needs to switch to the

HUAWEI CLOUD portal through the web UI, create a HUAWEI CLOUD account, and associate it with the customer's partner sales platform.

- If a customer has created an account on the partner sales platform and does not have a HUAWEI CLOUD account, the customer needs to switch to the HUAWEI CLOUD portal through the web UI, create a HUAWEI CLOUD account, and associate it with the customer's partner sales platform.

## 6.2 Managing Customers

### Service Object

Partner

### Scenario Description

Partners can view their associated customers and display the basic information such as the customer company names and customer real-name authentication status on the partner sales platform.

Partners can freeze accounts of customers associated with the partners in reseller model on the partner sales platform. When the accounts are frozen, the customers cannot purchase, renew the subscription to, change, or properly use the resources.

Partners can unfreeze accounts of customers associated with the partners in reseller model on the partner sales platform. After the accounts are unfrozen, fees generated when the customers purchase, renew the subscription to, and change resources are paid by the partners.

### Related APIs

| API                           | API Definition  |
|-------------------------------|---|
| Querying customers            | <a href="https://support.huaweicloud.com/eu/api-bpconsole/mc_00021.html">https://support.huaweicloud.com/eu/api-bpconsole/mc_00021.html</a> |
| Freezing a customer account   | <a href="https://support.huaweicloud.com/eu/api-bpconsole/mc_00027.html">https://support.huaweicloud.com/eu/api-bpconsole/mc_00027.html</a> |
| Unfreezing a customer account | <a href="https://support.huaweicloud.com/eu/api-bpconsole/mc_00028.html">https://support.huaweicloud.com/eu/api-bpconsole/mc_00028.html</a> |

### API Invoking Process

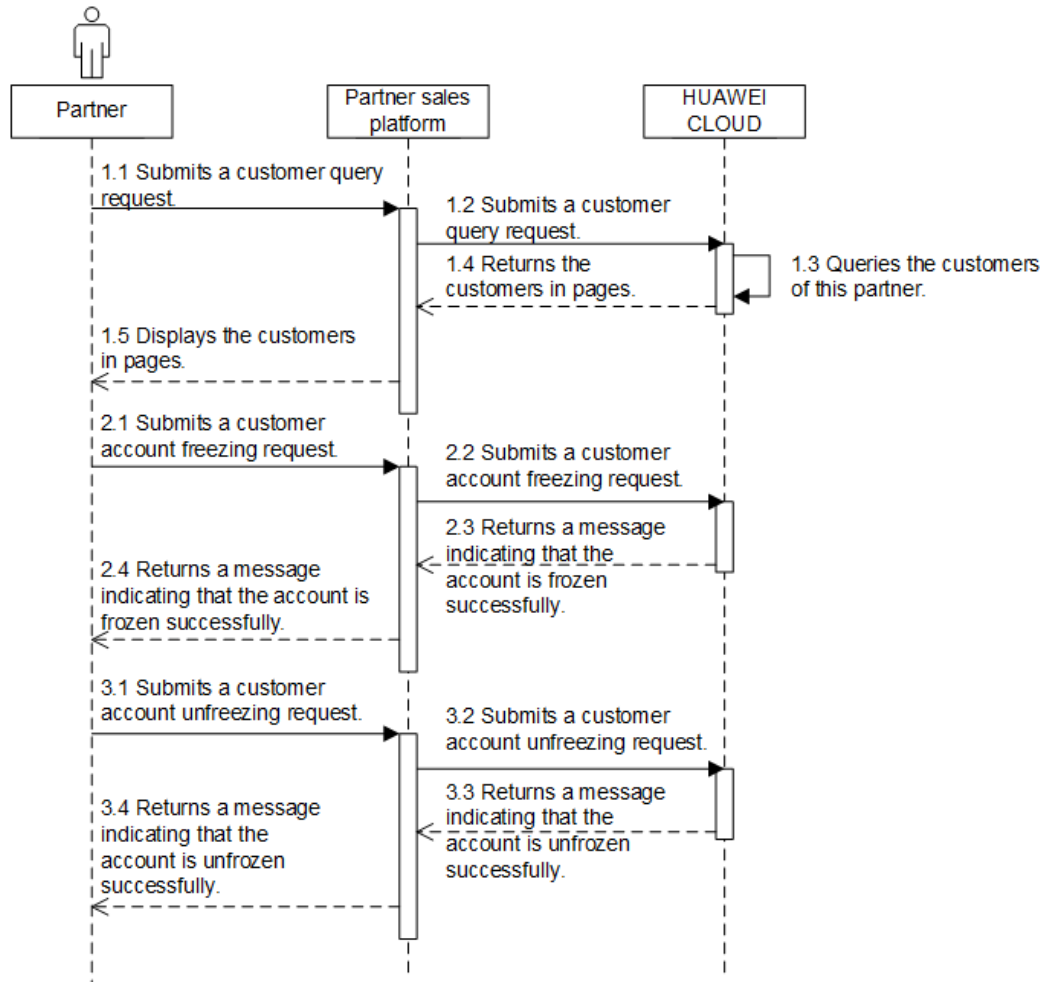

# 7 Transaction Management

---

## 7.1 Manage Customer Budgets

### Service Object

Partner

### Scenario Description

A customer's budget is used to control the total expenditures of a customer. A customer can purchase and renew cloud services on the partner sales platform only when the customer's account has sufficient budget.

If a customer is associated to a partner for the first time, the partner needs to configure a budget for the customer.

A partner can query and adjust the budgets of its customers on the partner sales platform. If the customer's budget cannot meet the customer's requirements, the partner needs to adjust the budget.

### Related APIs

| API                        | API Definition  |
|----------------------------|---|
| Querying customer budgets  | <a href="https://support.huaweicloud.com/eu/api-bpconsole/mt_01004.html">https://support.huaweicloud.com/eu/api-bpconsole/mt_01004.html</a> |
| Setting customers' budgets | <a href="https://support.huaweicloud.com/eu/api-bpconsole/mt_01005.html">https://support.huaweicloud.com/eu/api-bpconsole/mt_01005.html</a> |

### API Invoking Process



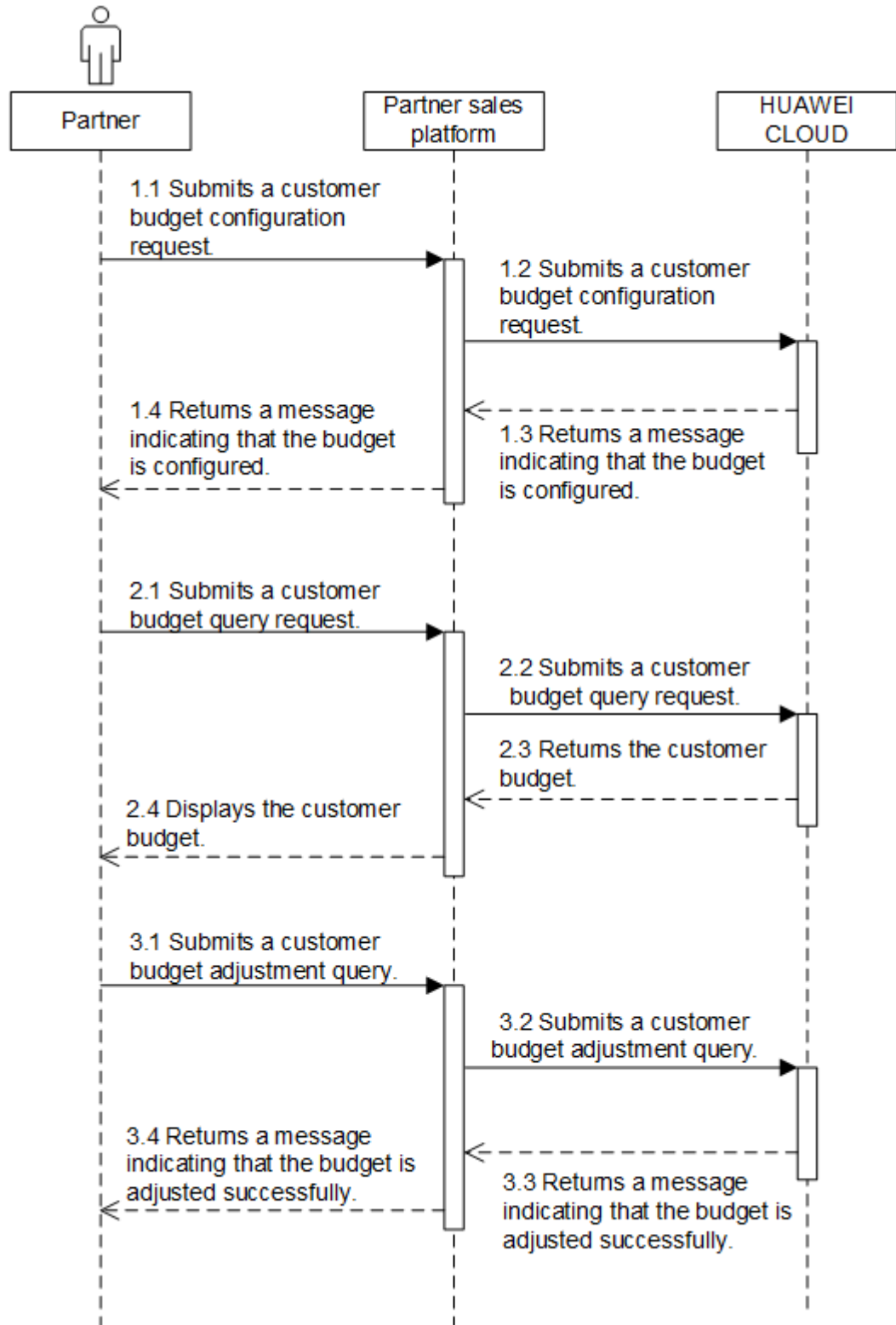

### Development Suggestions

- Customers' budgets are used to control the customers' total expenditures of each month. Partners need to configure proper budgets for the customers based on actual requirements.

- If the partner sales platform detects that a customer's budget is less than or equal to 0, the customer is forbidden to purchase or renew resources.
- The API for [configuring customer's budgets](#) is invoked when a partner sets the budget for a customer for the first time or adjusts the budget.

## 7.2 Coupon Management

### Service Object

Partner and its customers

### Scenario Description

A partner can view its issued coupons.

### Related APIs

| API              | API Definition  |
|------------------|---|
| Querying coupons | <a href="https://support.huaweicloud.com/eu/api-bpconsole/mp_02001.html">https://support.huaweicloud.com/eu/api-bpconsole/mp_02001.html</a> |

### API Invoking Process

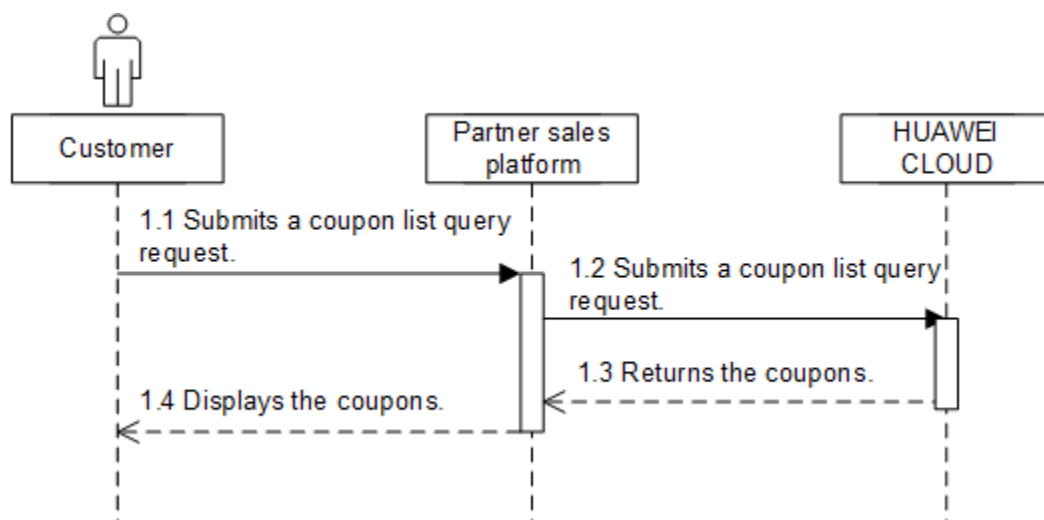

## 7.3 Managing Yearly/Monthly Orders

### Service Object

Customers of a partner

## Scenario Description

After purchasing yearly/monthly resources, a customer can perform the following operations on the partner sales platform:

- Query the orders in different statuses such as pending approval, processing, canceled, completed, and pending payment.
- Pay or cancel orders in the pending payment state, and unsubscribe from yearly/monthly products in the subscribed state.
- Query the available discounts of an order.
- Query the resources and original orders where the refund of an unsubscription or degrade order is from.

## Related APIs

| API  | API Definition  |
|--|---|
| Querying orders                                | <a href="https://support.huaweicloud.com/eu/api-bpconsole/api_order_00013.html">https://support.huaweicloud.com/eu/api-bpconsole/api_order_00013.html</a> |
| Querying order details                         | <a href="https://support.huaweicloud.com/eu/api-bpconsole/api_order_00014.html">https://support.huaweicloud.com/eu/api-bpconsole/api_order_00014.html</a> |
| Paying yearly/monthly product orders           | <a href="https://support.huaweicloud.com/eu/api-bpconsole/api_order_00030.html">https://support.huaweicloud.com/eu/api-bpconsole/api_order_00030.html</a> |
| Canceling orders in the pending payment status | <a href="https://support.huaweicloud.com/eu/api-bpconsole/api_order_00017.html">https://support.huaweicloud.com/eu/api-bpconsole/api_order_00017.html</a> |
| Querying refunds for orders                    | <a href="https://support.huaweicloud.com/eu/api-bpconsole/api_order_00020.html">https://support.huaweicloud.com/eu/api-bpconsole/api_order_00020.html</a> |

### API Invoking Process

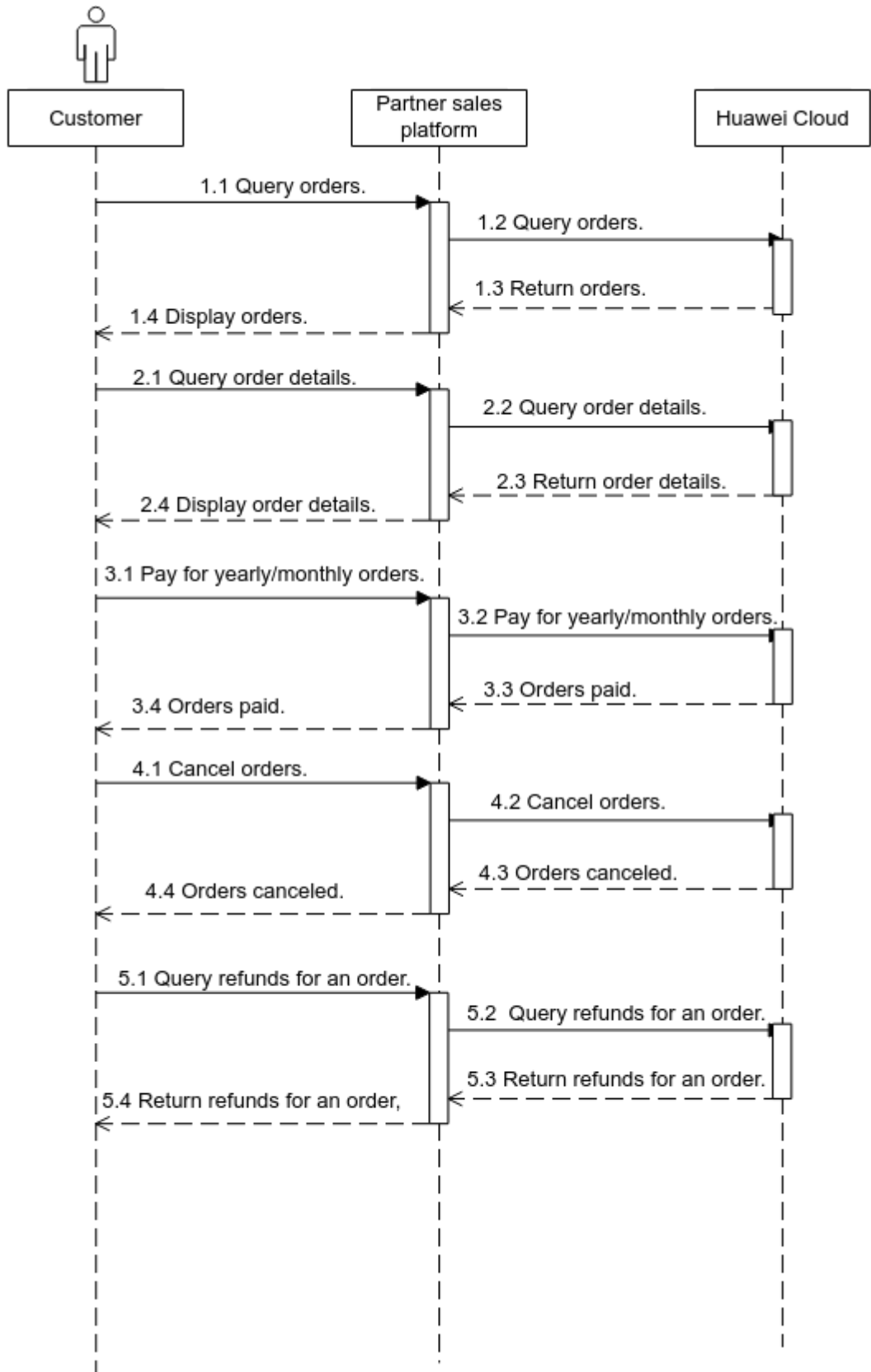

## Development Suggestions

The prerequisite for this scenario is that the customer has purchased yearly/monthly cloud service resources.

## 7.4 Managing Yearly/Monthly Resources

### Service Object

Customers of a partner

### Scenario Description

After purchasing yearly/monthly resources, a customer can perform the following operations on the partner sales platform:

- Query the expiration date of orders in the completed status, and renew the subscription to orders or resources about to expire.
- Configure automatic renewal for purchased yearly/monthly resources.
- Query the resources and original orders where the refund of an unsubscription or degrade order is from.

### Related APIs

| API  | API Definition  |
|--|---|
| Querying customer's yearly/monthly resources                                     | <a href="https://support.huaweicloud.com/eu/api-bpconsole/api_order_00021.html">https://support.huaweicloud.com/eu/api-bpconsole/api_order_00021.html</a> |
| Renewing subscription to yearly/monthly resources                                | <a href="https://support.huaweicloud.com/eu/api-bpconsole/api_order_00018.html">https://support.huaweicloud.com/eu/api-bpconsole/api_order_00018.html</a> |
| Unsubscribing from yearly/monthly resources                                      | <a href="https://support.huaweicloud.com/eu/api-bpconsole/api_order_00019.html">https://support.huaweicloud.com/eu/api-bpconsole/api_order_00019.html</a> |
| Enabling automatic subscription renewal for yearly/monthly resources             | <a href="https://support.huaweicloud.com/eu/api-bpconsole/api_order_00022.html">https://support.huaweicloud.com/eu/api-bpconsole/api_order_00022.html</a> |
| Disabling automatic subscription renewal for yearly/monthly resources            | <a href="https://support.huaweicloud.com/eu/api-bpconsole/api_order_00023.html">https://support.huaweicloud.com/eu/api-bpconsole/api_order_00023.html</a> |
| Enabling/Canceling the change from yearly/monthly to pay-per-use upon expiration | <a href="https://support.huaweicloud.com/eu/api-bpconsole/api_order_00024.html">https://support.huaweicloud.com/eu/api-bpconsole/api_order_00024.html</a> |

## API Invoking Process

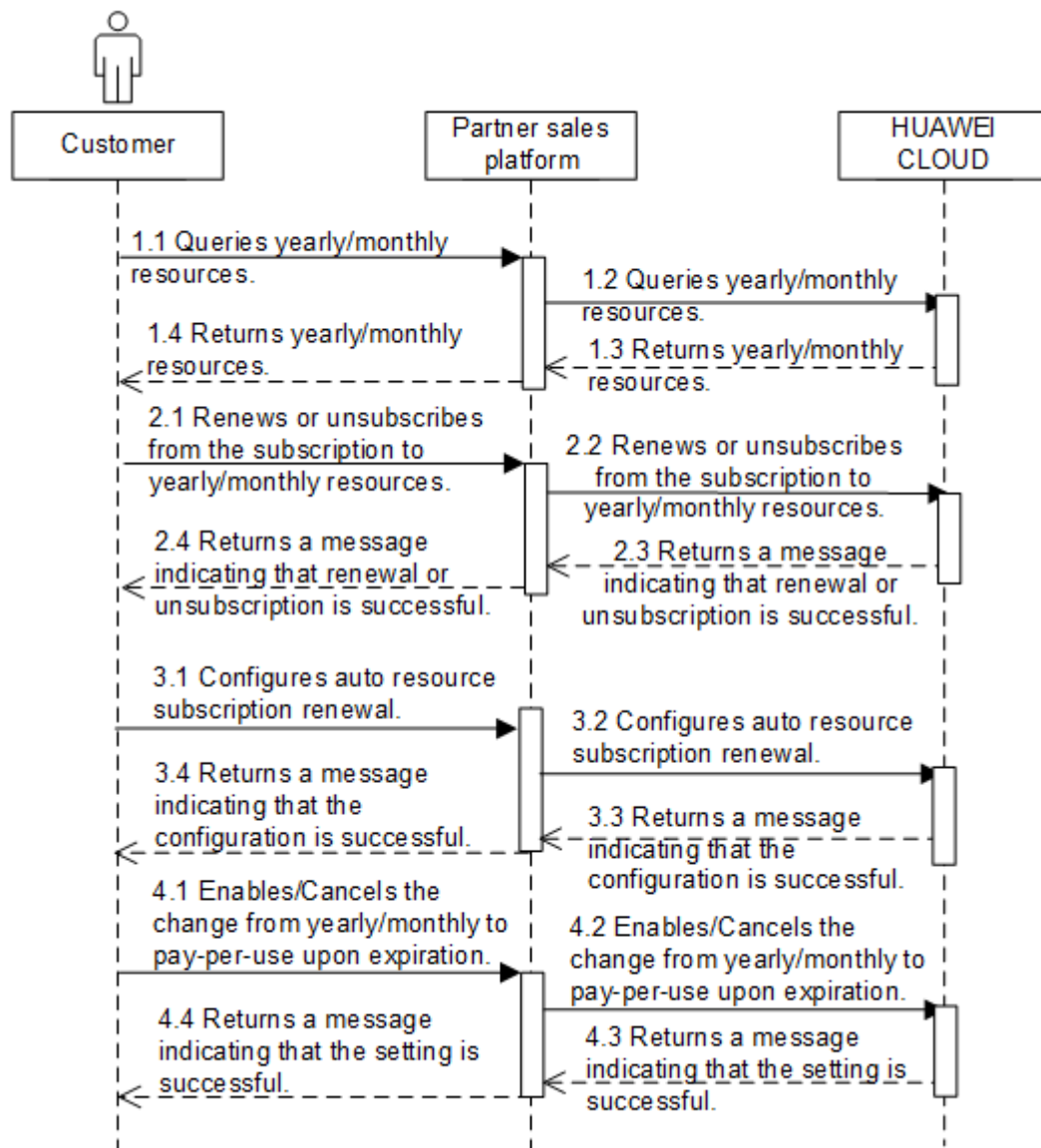

## Development Suggestions

- The prerequisite for this scenario is that a customer has purchased yearly/monthly cloud service resources.
- The resource IDs need to be obtained using the APIs for querying yearly/monthly resources because the management operations, such as subscribing to or unsubscribing from yearly/monthly resources, and enabling or disabling automatic subscription renewal, are performed based on resources.
- If a primary resource has attached resources and subscription to the primary resource is renewed or canceled, the system will also renew or cancel the subscription to the attached resources. An example of primary and attached resources are as follows: ECS is the primary resource, and its attached resources are EVS, VPC, EIP, and bandwidth.

- The fee of automatic subscription renewal for a product will be deducted at 03:00 seven days before the product is due. If the fee fails to deduct for the first time due to insufficient account balance, the system will attempt to deduct the fee at 03:00 every day before the reserved product resource expires until the fee is deducted successfully.

## 7.5 Managing Pay-Per-Use Resources

### Service Object

Partner's customers

### Scenario Description

After a customer purchases pay-per-use resources, it can query the provisioned ones on the partner sales platform.

### Related APIs

| API                                       | API Definition  |
|---|---|
| Querying customer's pay-per-use resources | <a href="https://support.huaweicloud.com/eu/api-bpconsole/mqr_01002.html">https://support.huaweicloud.com/eu/api-bpconsole/mqr_01002.html</a> |

### API Invoking Process

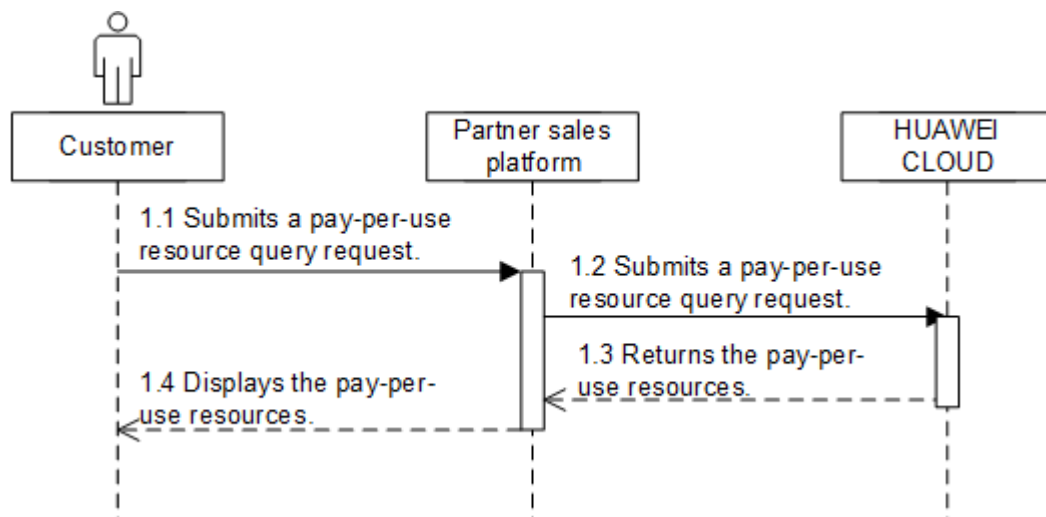

### Development Suggestions

The pay-per-use resource query has a latency, and therefore the data obtained from the API is for reference only.

## 7.6 Managing Resource Packages

### Service Object

Customers of a partner

### Scenario Description

After a customer purchases a resource package, the customer can query the resource package list and resource usage on the partner sales platform.

### Related APIs

| API                                | API Definition  |
|------------------------------------|---|
| Querying Resource Packages         | <a href="https://support.huaweicloud.com/eu/api-bpconsole/api_order_00027.html">https://support.huaweicloud.com/eu/api-bpconsole/api_order_00027.html</a> |
| Querying the Resource Usage        | <a href="https://support.huaweicloud.com/eu/api-bpconsole/api_order_00028.html">https://support.huaweicloud.com/eu/api-bpconsole/api_order_00028.html</a> |
| Querying Details of Resource Usage | <a href="https://support.huaweicloud.com/eu/api-bpconsole/api_order_00029.html">https://support.huaweicloud.com/eu/api-bpconsole/api_order_00029.html</a> |



## API Invoking Process

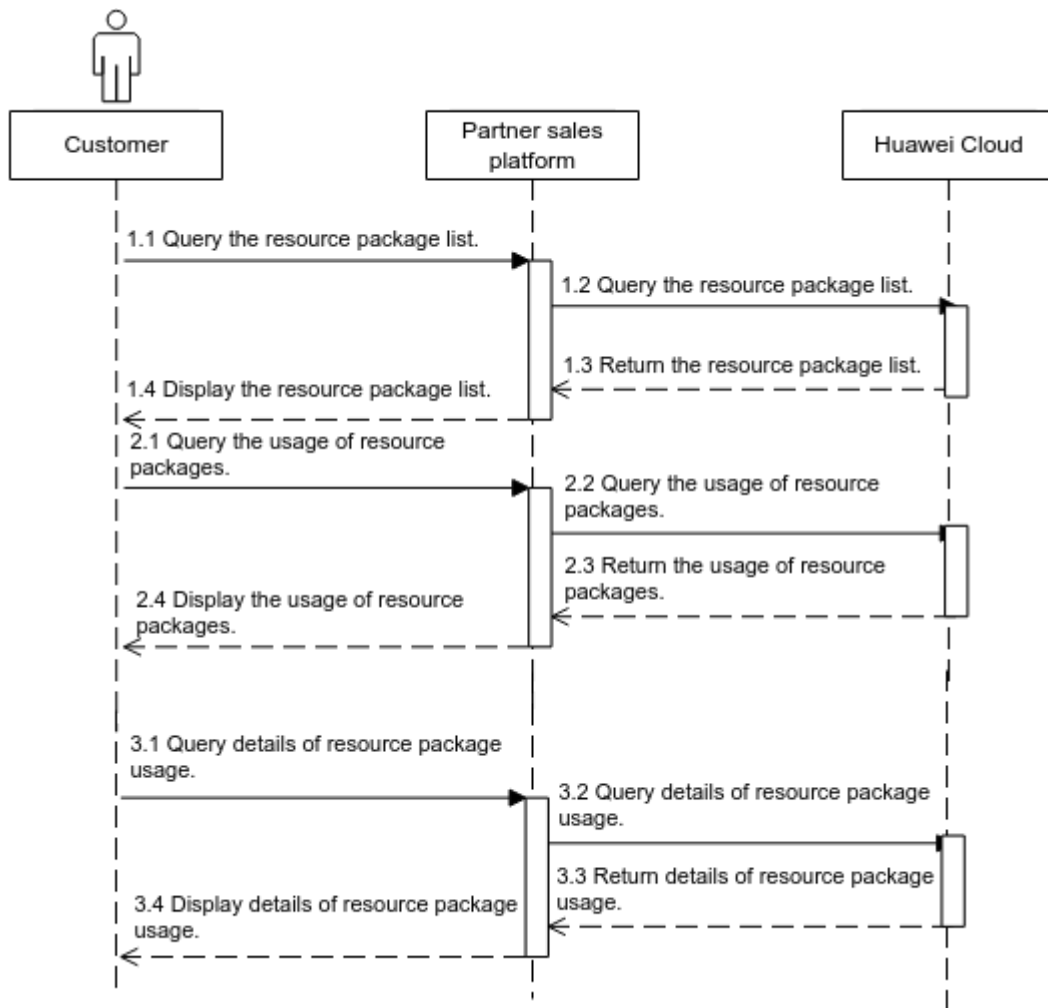

## Development Suggestions

The prerequisite for this scenario is that the customer has purchased a resource package.

# 8 Cloud Service Resource Management

---

## Service Object

Partner's customers

## Scenario Description

After a customer purchases cloud service resources, it can switch from the partner sales platform to the HUAWEI CLOUD portal to manage the purchased cloud service resources. Specifically, the customer can start, stop, or restart an ECS, attach an EVS disk to an ECS, expand the capacity of an EVS disk, create snapshots and backups for an EVS disk, create a VPC and configure subnets, as well as bind, unbind, or release an EIP.

## Related APIs

| API  | API Definition |
|--|----------------|
| Switching from the partner sales platform to the HUAWEI CLOUD portal | None           |

## API Invoking Process

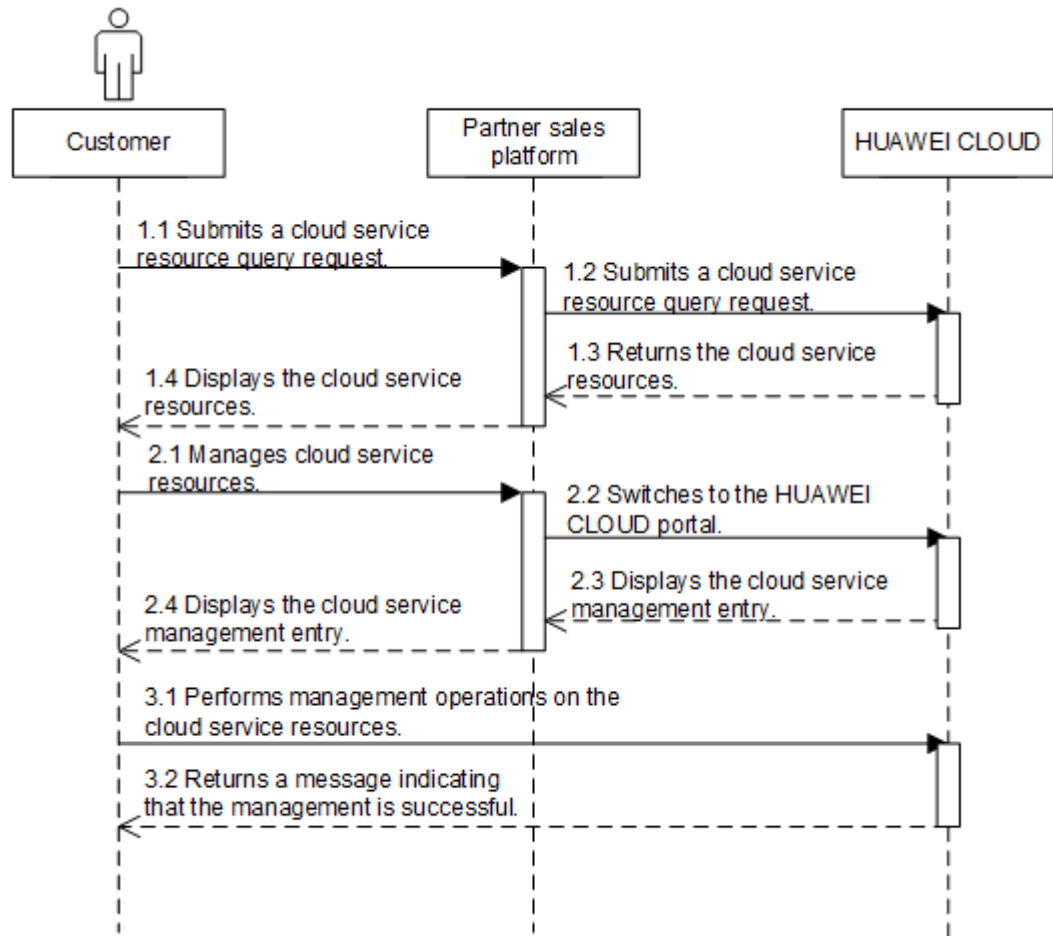

## Development Suggestions

Cloud service management is complex. Therefore, it is recommended to display the HUAWEI CLOUD portal in another tab or page for the cloud service management when customers switch from the partner sales platform.

# 9 Bill Management

---

## 9.1 Managing Customer Resource Usage

### Service Object

Partners

### Scenario Description

Partners subscribe to the customer resource usage on the **Support Center > API Management > Configure** page in Partner Center.

- Partners can view resource usage of its all customers or a specified customer on the partner sales platform.
- Customers can query their own resource usage.

### Related APIs

| API                              | API Definition  |
|----------------------------------|---|
| Querying customer resource usage | <a href="https://support.huaweicloud.com/eu/api-bpconsole/api_order_00009.html">https://support.huaweicloud.com/eu/api-bpconsole/api_order_00009.html</a> |

## API Invoking Process

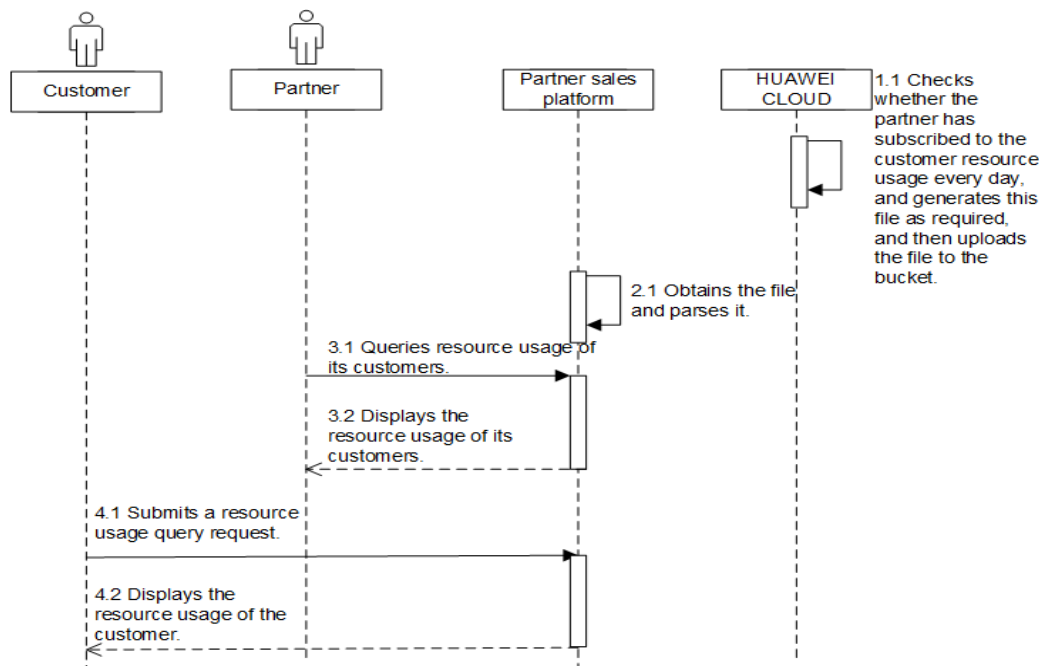

## Development Suggestions

- The system generates the customer resource usage file containing the data generated till the previous day from 12:00 to 20:00 (not later than 24:00) every day. Therefore, it is recommended to set the partner sales platform to obtain the customer resource usage file at 24:00 every day.
- The customer resource usage data has a latency. Therefore, the data cannot be used when the data accuracy requirement is high, such as for monitoring or budget control.

## 9.2 Partner Bill Management

### 9.2.1 Partner Bills

#### Service Object

Partner

#### Scenario Description

After a partner's customer purchases a cloud service product, the partner needs to settle the generated fee with HUAWEI CLOUD. The partner obtains the bills of the previous or earlier months from the partner sales platform, views the bill information including the bill amount and payment deadline, and then completes settlement with HUAWEI CLOUD.

After the settlement is complete, HUAWEI CLOUD will restore the budget of the customer.

## Related APIs

| API                    | API Definition  |
|------------------------|---|
| Querying monthly bills | <a href="https://support.huaweicloud.com/eu/api-bpconsole/mb_00003.html">https://support.huaweicloud.com/eu/api-bpconsole/mb_00003.html</a> |

## API Invoking Process

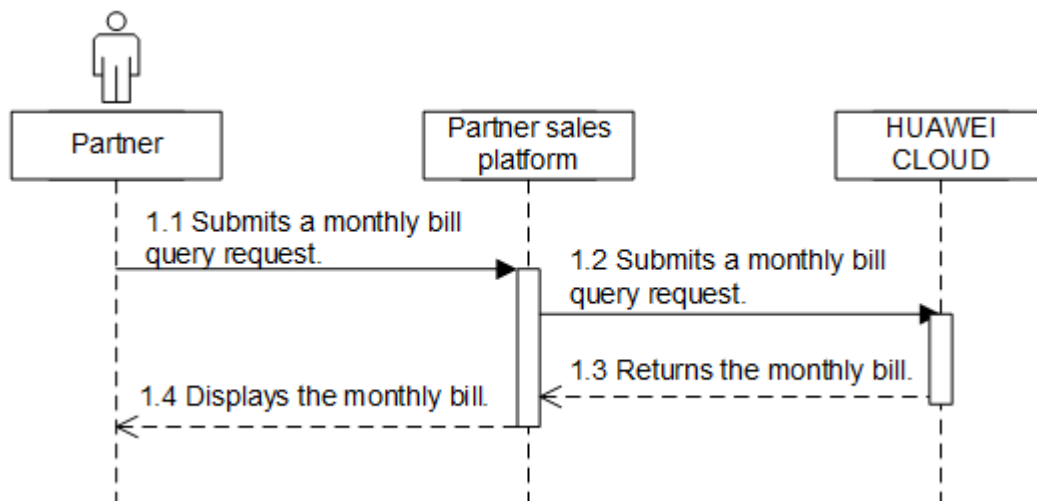

## Development Suggestions

- The partner bills of the last month are generated before 12:00 (Beijing time) on the fifth day of this month. Therefore, the partner can query the bills of the last month or earlier only.
- The refund contains the amount returned to the customer due to order cancellation or specifications changes.

## 9.2.2 Customer Bills

### Service Object

Partner's customers

### Scenario Description

After a partner subscribes to the partner bill (customer consumption details) on the **Support Center > API Management > Configure** page in Partner Center on HUAWEI CLOUD, the partner can rate its customers for the generated consumptions, and the partner sales platform will generate the customer bills based on this bill. The partner can perform reconciliation with HUAWEI CLOUD based on these customer bills.

## Related APIs

| API                           | API Definition  |
|-------------------------------|---|
| Querying monthly expenditures | <a href="https://support.huaweicloud.com/eu/api-bpconsole/mb_00002.html">https://support.huaweicloud.com/eu/api-bpconsole/mb_00002.html</a> |

## API Invoking Process

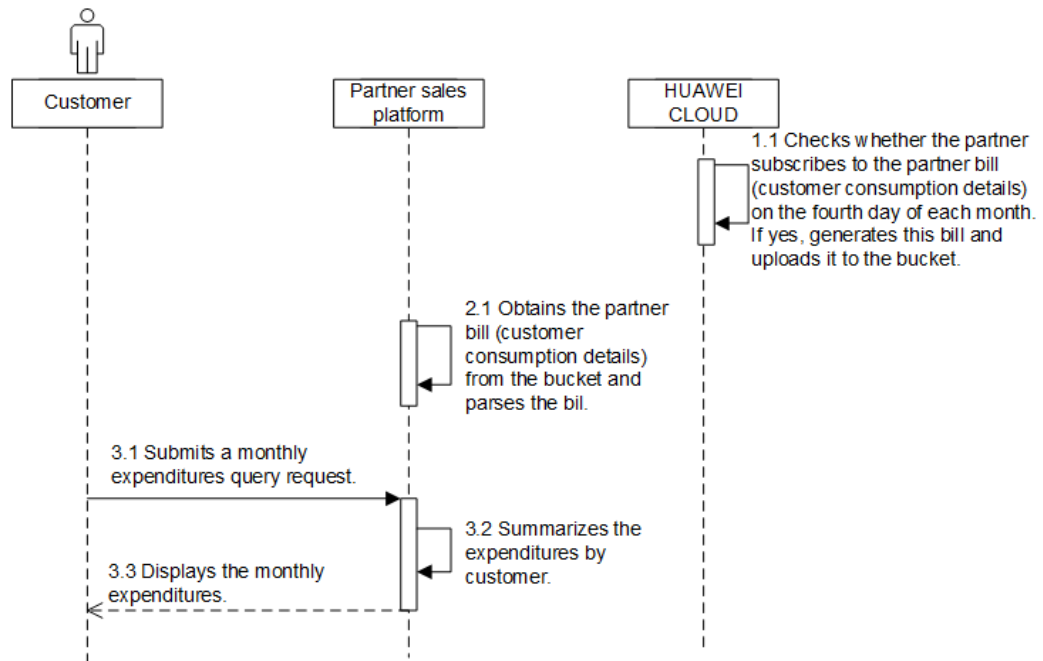

## Development Suggestions

- If a partner has subscribed to the partner bill (customer consumption details) in the HUAWEI CLOUD Partner Center, HUAWEI CLOUD will send the bill to the partner before 12:00 (Beijing time) on the fifth day of each month.
- The partner sales platform reads the bill and parses it. Then, the partner rates the consumptions of the customer based on this file, and the partner sales platform generates the customer expenditure bill.

# 10 Managing Service Tickets

---

## Service Object

Partner and its customers

## Scenario Description

1. A customer or partner creates a HUAWEI CLOUD service ticket on the partner sales platform. The partner sales platform forwards the service ticket to the HUAWEI CLOUD after-sales service team. When a customer or partner submits a service ticket, the customer or partner needs to enter the required information based on a template.
2. A customer or partner can query all the HUAWEI CLOUD service tickets or details of a HUAWEI CLOUD service ticket submitted by itself on the partner sales platform.
3. A customer or partner can perform operations on a service ticket submitted by itself, such as urging, deleting, closing, and canceling the service ticket. In addition, they can add messages on the service ticket details page, for example, adding confidential information, providing information required for the customer service handling the service ticket, or asking about the service ticket handling progress.

## Related APIs

For details, see [Service Ticket Open APIs](#).

## Related APIs

| API                             | API Definition |
|---------------------------------|----------------|
| Creating a service ticket       |                |
| Querying templates              |                |
| Querying service ticket list    |                |
| Querying service ticket details |                |



| API                                       | API Definition |
|---|----------------|
| Performing operations on a service ticket |                |
| Adding messages                           |                |

For details, see .

### API Invoking Process

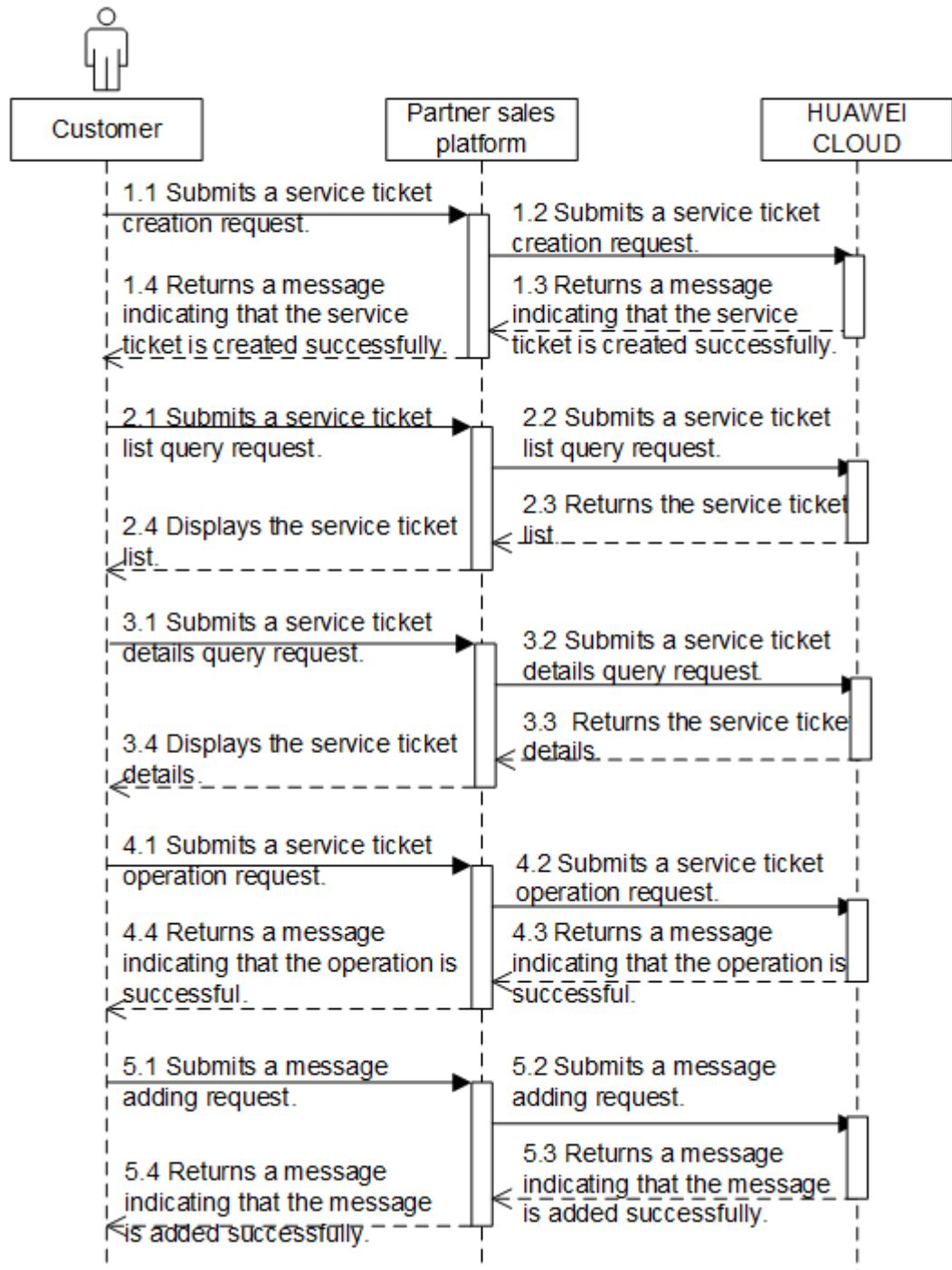

# 11 Appendix

## 11.1 Creating a Bucket

If a partner wants to query the file of the monthly bill details of a partner, the partner needs to create a bucket to store the monthly bill details files uploaded by HUAWEI CLOUD.

If a partner's customers buy products from HUAWEI CLOUD Chinese mainland website and want to perform real-name authentication, customers need to upload pictures of the certificates to a specified bucket for HUAWEI CLOUD to read to complete the real-name authentication.

You can create buckets on the Object Storage Service (OBS) management console. A bucket is a container for storing your data (objects) in OBS. Before you store data in OBS, you need to create a bucket. For details about how to create a bucket, see [Creating a Bucket](#).

### NOTE

- A partner account cannot be used to purchase resources. Therefore, partners need to use a common HUAWEI CLOUD account to log in to the system and create a bucket.
- To change a bucket, partners need to go to the configuration modification page, cancel subscription to all files, and disable attachment uploading for real-name authentication. Then, the partners can add a bucket on the configuration modification page.
- Different partners cannot share the same bucket.
- Only OBS buckets purchased on Huawei Cloud in the **EU-Ireland** region can be used.
- After the default encryption is enabled for a bucket, all objects uploaded to the bucket are encrypted. The **obs/default** key is used for encryption by default, and the files stored in the bucket cannot be downloaded.

|                    |                          |        |
|--------------------|--------------------------|--------|
| Default Encryption | <input type="checkbox"/> | Enable |
|--------------------|--------------------------|--------|

## 11.2 Obtaining the SP Metadata File

The **SP Metadata** file is the metadata file of the trustworthy SAML service provider. It contains the HUAWEI CLOUD SAML public key information and response path information.

If a partner switches to HUAWEI CLOUD from the partner sales platform **through the web UI**, the partner sales platform can check whether HUAWEI CLOUD SAML messages are reliable using this public key.

## Procedure

**Step 1** Sign in to Huawei Cloud as a partner. On the top navigation bar, select **Support > Open APIs**.

**Step 2** Click **Obtain SP Metadata File** under **Prepare**.

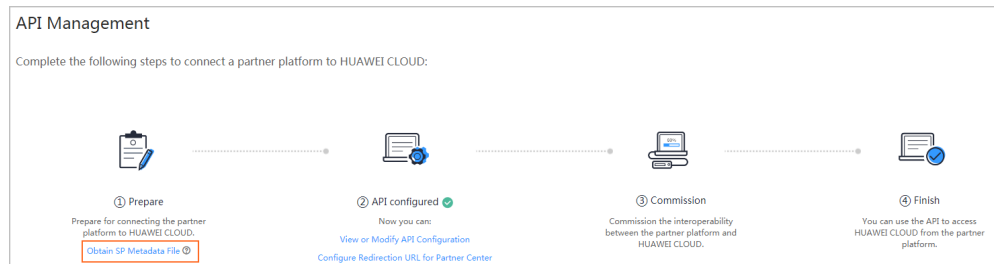

**Step 3** Upload the SP Metadata file to the IDP server of the partner's self-built platform. The file is used to verify the SAML message when a customer logs in to the partner's self-built platform and switches to HUAWEI CLOUD.

----End

## 11.3 Generating the IDP Metadata File

Before connecting to HUAWEI CLOUD, the partner sales platform needs to prepare the **IDP Metadata** file (metadata file of the enterprise identity provider). The file contains the SAML public key and response path information. If a partner switches to HUAWEI CLOUD from the partner sales platform **through the web UI**, HUAWEI CLOUD can check whether SAML messages from the partner sales platform are reliable using this public key.

### ⚠ CAUTION

Do not include sensitive IDP information, such as IDP user names, passwords, or other confidential information.

### Example of the IDP Metadata File (Saved Using UTF-8)

An example of the **IDP Metadata** generated based on the SAML2.0 protocol is as follows:

```
<?xml version="1.0"?>
<md:EntityDescriptor
  xmlns:md="urn:oasis:names:tc:SAML:2.0:metadata"
  xmlns:ds="http://www.w3.org/2000/09/xmldsig#" entityID="https://www.test.com">
  <md:IDPSSODescriptor protocolSupportEnumeration="urn:oasis:names:tc:SAML:2.0:protocol">
    <md:KeyDescriptor use="signing">
      <ds:KeyInfo
        xmlns:ds="http://www.w3.org/2000/09/xmldsig#">
        <ds:X509Data>
```

```

<ds:X509Certificate>
MIICsDCCAhmGAWIbAgUAAKNbH+B0Vm9HMA0GCSqGSIb3DQEBAQUAMEUxZzA1BgNV
BAYTAKFVMRMmWwEQYDVQGEWpTb211LVN0YXRIMSEwHwYDVQQKEWhhbnRlcm5ldCBX
aWRnaXRzIFB0eSBMdGQwHhcNMTgxMDMwMDIxMzA4WHcNMzMxMDMxMDIxMzA4WjBF
MQswCQYDVQQGEWJBVTETMBEGA1UECBMKU29tZS1TdGF0ZTEhMB8GA1UEChMYSW50
ZXJlZXQvV2lkZ210cyBQdHkgTHRkMIGfMA0GCSqGSIb3DQEBAQUAA4GNADCBiQKB
gQDIIZtsLpQLDpXB1LI8tbtwoeOyJbM2P1xJTOqRm1ZM0r7rpvt4kFCgAd68gAsl
YAEeSqUawxV3FUgt62DLMOT2auwBcPywVW7L/ZF4IUziwuFQLWdw5NIGMP5pt1M
HSe18k4paokoXAwZ2B+Vtku+kDTGLc3cp1T5/CIYE/ofdQIDAQABo4GnMIGkMB0G
A1UdDgQWBRRVZlu4B6TzuNHAsJz5tHoMilKldjB1BgNVHSMEljBsgBRVZlu4B6Tz
uNHAsJz5tHoMilKldjFpEcwRTElMAkGA1UEBhMCQVUxZzA1BgNVBAGTCiNvbWUt
U3RhdGUxITAFBgNVBAoTGEIudGVybmV0IFdpZGdpdHMgUHR5IEx0ZiUAAKNbH+B0
Vm9HMAwGA1UdEwQFMAMBAf8wDQYJKoZIhvcNAQEFBQADgYEAhyVdBqW4r94XdwMy
LK42mwqNnHy4WjM8eq9X5FhBckZX+TyM909iH2AsMjpkv8BDIxTiX6tpmNyYhOCp
vCPMmQH19450maIA7At//sEgL94FNRJbTYkme7F3x190X0htMr23Yan31IRwdj53
DgagnkMlzQ8QccUXrdQgzXzKb0w=</ds:X509Certificate>
</ds:X509Data>
</ds:KeyInfo>
</md:KeyDescriptor>
<md:KeyDescriptor use="encryption">
<ds:KeyInfo
xmlns:ds="http://www.w3.org/2000/09/xmldsig#">
<ds:X509Data>
<ds:X509Certificate>
MIICsDCCAhmGAWIbAgUAAKNbH+B0Vm9HMA0GCSqGSIb3DQEBAQUAMEUxZzA1BgNV
BAYTAKFVMRMmWwEQYDVQGEWpTb211LVN0YXRIMSEwHwYDVQQKEWhhbnRlcm5ldCBX
aWRnaXRzIFB0eSBMdGQwHhcNMTgxMDMwMDIxMzA4WHcNMzMxMDMxMDIxMzA4WjBF
MQswCQYDVQQGEWJBVTETMBEGA1UECBMKU29tZS1TdGF0ZTEhMB8GA1UEChMYSW50
ZXJlZXQvV2lkZ210cyBQdHkgTHRkMIGfMA0GCSqGSIb3DQEBAQUAA4GNADCBiQKB
gQDIIZtsLpQLDpXB1LI8tbtwoeOyJbM2P1xJTOqRm1ZM0r7rpvt4kFCgAd68gAsl
YAEeSqUawxV3FUgt62DLMOT2auwBcPywVW7L/ZF4IUziwuFQLWdw5NIGMP5pt1M
HSe18k4paokoXAwZ2B+Vtku+kDTGLc3cp1T5/CIYE/ofdQIDAQABo4GnMIGkMB0G
A1UdDgQWBRRVZlu4B6TzuNHAsJz5tHoMilKldjB1BgNVHSMEljBsgBRVZlu4B6Tz
uNHAsJz5tHoMilKldjFpEcwRTElMAkGA1UEBhMCQVUxZzA1BgNVBAGTCiNvbWUt
U3RhdGUxITAFBgNVBAoTGEIudGVybmV0IFdpZGdpdHMgUHR5IEx0ZiUAAKNbH+B0
Vm9HMAwGA1UdEwQFMAMBAf8wDQYJKoZIhvcNAQEFBQADgYEAhyVdBqW4r94XdwMy
LK42mwqNnHy4WjM8eq9X5FhBckZX+TyM909iH2AsMjpkv8BDIxTiX6tpmNyYhOCp
vCPMmQH19450maIA7At//sEgL94FNRJbTYkme7F3x190X0htMr23Yan31IRwdj53
DgagnkMlzQ8QccUXrdQgzXzKb0w=
</ds:X509Certificate>
</ds:X509Data>
</ds:KeyInfo>
</md:KeyDescriptor>
<md:SingleLogoutService Binding="urn:oasis:names:tc:SAML:2.0:bindings:HTTP-Redirect"
Location="https://www.test.com/saml/logout"/>
<md:NameIDFormat>urn:oasis:names:tc:SAML:2.0:nameid-format:transient</md:NameIDFormat>
<md:SingleSignOnService Binding="urn:oasis:names:tc:SAML:2.0:bindings:HTTP-Redirect"
Location="https://www.test.com/saml/login"/>
</md:IDPSSODescriptor>
</md:EntityDescriptor>

```

## Parameter Description

Change the content in bold tags in the preceding example based on the site requirements. For details about the parameters, see [Table 11-1](#).

**Table 11-1** Parameter description

| Parameter | Description   |
|-----------|---|
| entityID  | Indicates the unique partner ID.<br>You are advised to use a domain name and ensure that the value is globally unique. The value must contain <b>https://</b> .<br>Example: <b>https://www.test.com</b> |

| Parameter                                 | Description  |
|---|--|
| <ds:X509Certificate></ds:X509Certificate> | Indicates a certificate containing the public key, which is used for signature verification. To ensure security, you are advised to use a public key greater than or equal to 2048 bits. HUAWEI CLOUD uses the signature certificate in the <b>IDP Metadata</b> file to verify the credibility and integrity of messages transmitted during the authentication.<br><br>For details, see <a href="#">Generating a Certificate</a> . |
| Location in <md:SingleLogoutService>      | The partner IDP server provides the session deregistration function. After a partner's customer deregisters a session in HUAWEI CLOUD IAM, a message is returned to the address in server redirection mode.<br><br>Example: <a href="https://www.test.com/saml/logout">https://www.test.com/saml/logout</a>  |
| Location in <md:SingleSignOnService>      | Indicates the address for the IDP server of the partner sales platform processing SAML requests during SSO. The server redirection mode is used. This address is defined by partners for receiving and processing SAML requests and generating SAML responses.<br><br>Example: <a href="https://www.test.com/saml/login">https://www.test.com/saml/login</a>   |

## 11.4 Sample Code for Parsing the SAMLRequest

- Sample code of the "URL decoding > decoding with Base64 > decompressing (zip.inflate)" process

```
package org.apache;
import java.io.*;
import org.opensaml.xml.util.Base64;
import java.util.zip.InflaterInputStream;
import java.util.zip.Inflater;
class SamlRequestDecoder {
    public static void main(String[] args) throws UnsupportedEncodingException {
        String samlRequest = "hZJBb9swDIX%2Fiqa77dho0kylU2QNigboNq9xd9hIkGwM1ipLsSjF7b
%2Bv7KRbhwHZISK%2FR73HxdVzq8gBLEqjc5rGEOpAC1NL%2FZjTh
%2FImmtOr5QJ5q7I9W3nX6HvoPKAjYVAjO77k1FvNDEeJTPMWkDnBtqvPdyLJ2xvJTPCKEpWiGBdkLo2
Gn0Ldgv2IAU83N
%2FItHFujxJeFCJG897kEIZX8fCtGPRy2SQSwbwPyRK1mErqbkbfzLAAqvpXajG07SHauT4MJJaEhWovXDLi
EwHaefuSgMAPyjkKfdvHXAwYSm6MFTB%2BO6c7rhAo2axz%2BtM12ZOqZ7rreDdT1aHqU9F1T5Wqs
%2FYSm19TefkcWrHgiPIAf4YRPWw0Oq5dTrNJOo%2F5NMpm5eQjS1M2nccXF7MflBQnyz5JfYzinL
%2FVsQnZbVkwUff1W1Ly%2F53S0EBPAbJR3b5P7jyYv5IMl2fDWSTv%2Bb%2FP5UsAbtaFUVK8kJVSpr
%2B2wF1ww1kPo7ktd%2BdXGcqjnzjK3OWa5QhL0q2xYD%2F5rmSOwn2P%2BdDk%2BVpyb
%2BvePkk";
        byte[] decodedBytes = Base64.decode(java.net.URLDecoder.decode(samlRequest, "utf-8"));
        try {
            ByteArrayInputStream bytesIn = new ByteArrayInputStream(decodedBytes);
            InflaterInputStream in = new InflaterInputStream(bytesIn, new Inflater(true));
            byte[] buffer = new byte[decodedBytes.length];
            ByteArrayOutputStream out = new ByteArrayOutputStream();
            for (int bytesRead = 0; bytesRead != -1; bytesRead = in.read(buffer)) {
                out.write(buffer, 0, bytesRead);
            }
            System.out.println(new String(out.toByteArray(), "UTF-8"));
        }
        catch (Exception e) {
        }
    }
}
```

```
}  
}
```

- The parsed **samlRequest.xml** content is similar to the following:

```
<?xml version="1.0" encoding="UTF-8"?>  
<saml2p:AuthnRequest xmlns:saml2p="urn:oasis:names:tc:SAML:2.0:protocol"  
AssertionConsumerServiceURL="https://auth.huaweicloud.com/authui/saml/SAMLAssertionConsumer"  
Destination="https://avatar.huawei.com/nidp/saml2/sso" ForceAuthn="false"  
ID="_dck4mm08qmdhc8k4nuir07ghetdqqg8umg5" IsPassive="false"  
IssueInstant="2018-11-20T03:19:38.368Z"  
ProtocolBinding="urn:oasis:names:tc:SAML:2.0:bindings:HTTP-POST" Version="2.0">  
  <saml2:Issuer xmlns:saml2="urn:oasis:names:tc:SAML:2.0:assertion">https://  
  auth.huaweicloud.com/</saml2:Issuer>  
  <saml2p:NameIDPolicy AllowCreate="true" Format="urn:oasis:names:tc:SAML:2.0:nameid-  
  format:transient" SPNameQualifier="https://auth.huaweicloud.com/" />  
</saml2p:AuthnRequest>
```

## 11.5 How Do I Check the Partner ID?

You can obtain the partner ID on the **My Credentials** page.

- Step 1** Sign in to [Huawei Cloud](#) as a partner.
- Step 2** In the drop-down list of your account name, click **Partner Center** to go to the Partner Center.
- Step 3** Under the account name, select **Partner Information > Basic Information**.
- Step 4** Click **Account Information**.

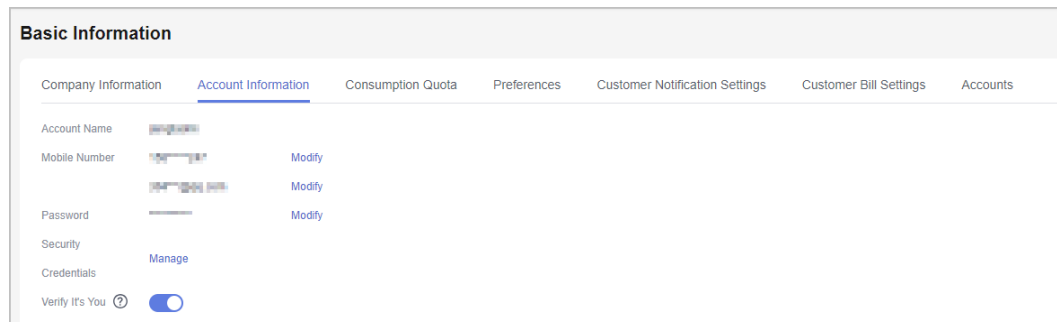

- Step 5** Click **Manage**.

On **My Credentials** page, check the **Account ID**, which is your partner ID.

|                             |   |                        |
|-----------------------------|---|------------------------|
| Username                    | [Redacted]  |                        |
| User ID                     | [Redacted]  |                        |
| Account Name                | [Redacted]  |                        |
| Account ID                  | [Redacted]  |                        |
| Verified Email Address      | [Redacted]  | <a href="#">Change</a> |
| Mobile Number               | [Redacted]  | <a href="#">Change</a> |
| Password                    | Security Strong <span>Weak</span> <span>Medium</span> <span>Strong</span> | <a href="#">Change</a> |
| Login Authentication Method | Disable   | <a href="#">Change</a> |
| Virtual MFA Device          | <span>Unbound</span>   <a href="#">Bind</a>                               |                        |

----End

## 11.6 How Do I Obtain the xaccountType Value?

The xaccountType value is the system ID of your partner sales platform. You can obtain the ID of your partner sales platform on the **Configure** page.

### NOTICE

To obtain the value of **xaccountType**, you need to configure the access parameters on the **Support > Open APIs** page of Partner Center first.

For details, see [Basic Configuration](#).

After you configure the access parameters, you can obtain the **xaccountType** value (**Partner Platform ID** value) on the **Configure** page.

✓ API access configured successfully.
 Download Metadata File   Modify

**Basic Information**

**Partner Platform ID:** [Redacted]

Company Name: [Redacted]

Notification URL: [Redacted]

**Contact Information**

⊗ --     
 📄 --     
 ✉ --



## 11.7 Generating a Certificate

A partner can purchase certificates issued by commercial CA or use OpenSSL to generate free certificates. There are many OpenSSL commands for generating certificates. This section describes the recommended OpenSSL commands.

**Step 1** Generate the RSA public-private key pair of CA.

Command: **openssl genrsa [-out *filename*] [-aes256] [*numbits*]**

Example: **openssl genrsa -out CAkey.pem -aes256 2048**

When the command is executed, a message is displayed on the OpenSSL UI to prompt you to manually enter the password of the generated private key file. The password automatically derives an encryption key and encrypts the private key file.

**Table 11-2** Parameter description

| Parameter               | Description  |
|-------------------------|--|
| [-out <i>filename</i> ] | Indicates the name and path of the file that stores the public-private key pair.   |
| [-aes256]               | Indicates that the encryption algorithm is AES256-CBC. You can also use other encryption algorithms, such as <b>-des</b> , <b>-des3</b> , <b>-aes128</b> , and <b>-idea</b> . The recommended symmetric encryption algorithms are AES (128 or higher bits). Therefore, AES256 is recommended. If no encryption algorithm is specified in the command for generating the public-private key pair, the generated key-pair file is not protected by the password. |
| [ <i>numbers</i> ]      | Indicates the length of the generated public-private key pair. The recommended asymmetric encryption algorithm is RSA (2048 bits or higher). Therefore, the recommended length of the public-private key pair has 2048 bits.   |

```
ecs-5052:/etc/ssl # openssl genrsa -out CAkey.pem -aes256 2048
Generating RSA private key, 2048 bit long modulus
.....+++
e is 65537 (0x10001)
Enter pass phrase for CAkey.pem:
Verifying - Enter pass phrase for CAkey.pem:
ecs-5052:/etc/ssl #
```

**Step 2** Use the CA private key to perform self signature and generate a root certificate.

Command: **openssl req [-x509] [-new] [-key *filename*] [-out *filename*] [-md2|-md5|-sha1|-mdc2|-sha256] [-days *n*] [-config *path of openssl.cnf*]**

Example: **openssl req -x509 -new -key CAkey.pem -sha256 -out CA.pem -days 3650 -config openssl.cnf**

In the example, **Cakey.pem** is the private key file generated in **Step 1**. When the command is executed, a message is displayed on the OpenSSL UI to prompt you to manually enter the password of the private key file generated in **Step 1** and information of the certificate applicant.

**Table 11-3** Parameter description

| Parameter                       | Description   |
|---------------------------------|---|
| [-x509]                         | Generates the root CA certificate. The extension item of the certificate is specified in the <b>config</b> file.  |
| [-new]                          | Generates a new Certificate Secure Request (CSR) file. If this parameter is used together with <b>-x509</b> , a self-signed root certificate file is generated. In this case, you need to enter the necessary information for creating a CSR file. The required information is defined in the <b>config</b> file.                 |
| [-key filename]                 | Indicates the source of the certificate private key file. The format of the file is <b>PKCS#8</b> .   |
| [-out filename]                 | Generates the certificate request file. If <b>-x509</b> is specified, a self-signed root certificate file is generated. By default, a standard CSR file is generated.   |
| [-md2]-md5 -sha1 -mdc2 -sha256] | Indicates the hash algorithm of the certificate. It is recommended to use SHA256 in the signature scenario. In addition, because the RSA public-private key pair is generated in <b>Step 1</b> , the signature algorithm specified here is SHA256RSA.   |
| [-days n]                       | Indicates the validity period of the certificate with the signature. If this parameter is not specified, the validity period of the generated certificate is 30 days (default). Generally, it is recommended to set the validity period of the generated certificate to 10 years. That is, the value of <b>n</b> is <b>3650</b> . |
| [-config path of openssl.cnf]   | Indicates the name and path of the <b>openssl.cnf</b> configuration file.   |

```
ecs-5052:/etc/ssl # openssl req -x509 -new -key Cakey.pem -sha256 -out CA.pem -days 3650 -config openssl.cnf
Enter pass phrase for Cakey.pem:
You are about to be asked to enter information that will be incorporated
into your certificate request.
What you are about to enter is what is called a Distinguished Name or a DN.
There are quite a few fields but you can leave some blank
For some fields there will be a default value,
If you enter '.', the field will be left blank.
-----
Country Name (2 letter code) [AU]:
State or Province Name (full name) [Some-State]:
Locality Name (eg, city) []:
Organization Name (eg, company) [Internet Widgits Pty Ltd]:
Organizational Unit Name (eg, section) []:
Common Name (e.g. server FQDN or YOUR name) []:
Email Address []:
```

**Step 3** Generates the public-private key pair of the device certificate.

The command for generating the public-private key pair of the device certificate. The command is the same as that for generating the public-private key-pair of the CA certificate.

Example: **openssl genrsa -out Devicekey.pem -aes256 2048**

**Devicekey.pem** is the file that stores the public-private key of the device certificate. When the command is executed, a message is displayed on the OpenSSL UI to prompt you to manually enter the password of the generated private key file. The password automatically derives an encryption key and encrypts the private key file.

```
ecs-5052:/etc/ssl # openssl genrsa -out Devicekey.pem -aes256 2048
Generating RSA private key, 2048 bit long modulus
.....+++
.....+++
e is 65537 (0x10001)
Enter pass phrase for Devicekey.pem:
Verifying - Enter pass phrase for Devicekey.pem:
```

**Step 4** Generates a CSR file of the device certificate.

Command: **openssl req [-new] [-key filename] [-out filename] [-config path of openssl.cnf]**

Example: **openssl req -new -key Devicekey.pem -out DeviceCert.csr -config openssl.cnf**

In the example, **Devicekey.pem** is the private key file generated in [Step 3](#). When the command is executed, a message is displayed on the OpenSSL UI to prompt you to manually enter the password of the private key file generated in [Step 3](#) and information of the certificate applicant.

[Table 11-3](#) describes the parameters.

```
ecs-5052:/etc/ssl # openssl req -new -key Devicekey.pem -out DeviceCert.csr -config openssl.cnf
Enter pass phrase for Devicekey.pem:
You are about to be asked to enter information that will be incorporated
into your certificate request.
What you are about to enter is what is called a Distinguished Name or a DN.
There are quite a few fields but you can leave some blank.
For some fields there will be a default value,
If you enter '.', the field will be left blank.
-----
Country Name (2 letter code) [AU]:
State or Province Name (full name) [Some-State]:
Locality Name (eg, city) []:
Organization Name (eg, company) [Internet Widgits Pty Ltd]:
Organizational Unit Name (eg, section) []:
Common Name (e.g. server FQDN or YOUR name) []:
Email Address []:

Please enter the following 'extra' attributes
to be sent with your certificate request
A challenge password []:
An optional company name []:
```

**Step 5** Use the CA private key to issue the device certificate.

Command: **openssl x509 [-req] [-in filename] [-out filename] [-CA filename] [-CAkey filename] [-md2|-md5|-sha1|-mdc2|-sha256] [-days arg] [-CAcreateserial] [-extfile filename] [-extensions v3\_req]**

Example: **openssl x509 -req -in DeviceCert.csr -out DeviceCert.pem -CA CA.pem -CAkey CAkey.pem -sha256 -days 3650 -CAcreateserial -extensions v3\_req -extfile openssl.cnf**

When the command is executed, a message is displayed on the OpenSSL UI to prompt you to manually enter the password of the CA root private key file generated in [Step 1](#).

**Table 11-4** Parameter description

| Parameter                       | Description   |
|---------------------------------|---|
| [-req]                          | Indicates that the input file (the file following the <b>-in</b> parameter) is the CSR file (in x509 commands).   |
| [-in filename]                  | Indicates the name of the input file. The file is the CSR file of the device certificate generated in <a href="#">Step 4</a> .  |
| [-out filename]                 | Indicates the name of the generated file. The file is the device certificate file.  |
| [-CA filename]                  | Indicates the name of the CA certificate file for signature, that is, the CSR file generated in <a href="#">Step 2</a> .  |
| [-CAkey filename]               | Indicates the CA private key file, that is, the RSA public-private key pair of CA generated in <a href="#">Step 1</a> .   |
| [-md2 -md5 -sha1 -mdc2 -sha256] | Indicates the hash algorithm of the certificate. It is recommended to use SHA256 in the signature scenario. In addition, because the RSA public-private key pair is generated in <a href="#">Step 1</a> , the signature algorithm specified here is SHA256RSA.  |
| [-days n]                       | Indicates the validity period of the certificate with the signature. If this parameter is not specified, the validity period of the generated certificate is 30 days (default). Generally, it is recommended to set the validity period of the generated certificate to 10 years. That is, the value of <b>n</b> is <b>3650</b> .   |
| [-CAcreateserial]               | If there is no CA serial number file (default file name <b>CA.srl</b> ), one CA serial number file will be generated. If there is a default CA serial number file, the default file is used. The serial number increases by one every time when a certificate is issued.  |
| [-extfile filename]             | Indicates the name of the file containing the certificate extension item. In the example, the file name is <b>openssl.cnf</b> . If this parameter is not specified, the generated certificate does not contain any extension item, that is, the generated certificate is of the x.509 v1 version.   |
| [-extensions section]           | Indicates the extended items in the issued certificate file. If this parameter is not specified, the default value is <b>v3_ca</b> , indicating that a CA root certificate is generated. In this example, the device certificate is to be issued. Therefore, the <b>section</b> value is set to <b>v3_req</b> , indicating that the basic constraint of the generated certificate is <b>Subject Type=End Entity</b> (the certificate is a terminal entity certificate). |

```
ecs-5052:/etc/ssl # openssl x509 -req -in DeviceCert.csr -out DeviceCert.pem -CA CA.pem -CAkey CAkey.pem -sha256 -days 3650 -CAcreateserial -extensions v3_req -extfile openssl.cnf
Signature ok
subject=C=CN, ST=, L=, O=, OU=, CN=, emailAddress=
Getting CA Private Key
Enter pass phrase for CAkey.pem:
```

**Step 6** The body of the **DeviceCert.pem** file (excluding the header and tail of the file) generated in **Step 5** is the values of `<ds:X509Certificate>` `</ds:X509Certificate>` in **Example of the IDP Metadata File (Saved Using UTF-8)**.

----End

## 11.8 HUAWEI CLOUD Environment and Address

| Environment                   | Description   | Address   |
|-------------------------------|---|---|
| Login address provided by IAM | Indicates the address provided by IAM for the partner to switch to the page from the partner sales platform for registering or associating a HUAWEI CLOUD account. It is not the API path (endpoint) provided by IAM. | <a href="https://auth.eu.huaweicloud.com/authui/login.html">https://auth.eu.huaweicloud.com/authui/login.html</a> |

| Environment                                      | Description   | Address  |
|--|---|--|
| Address of obtaining the <b>SP Metadata</b> file | The partner needs to upload the <b>SP Metadata</b> file to the IDP server on the partner sales platform, use the public key in the <b>SP Metadata</b> file to verify the message received from HUAWEI CLOUD, and establish the trust relationship with IAM. | <p>The <b>unsigned</b> parameter indicates whether to sign the packet and is optional. Signature verification prevents the file content from being tampered with.</p> <ul style="list-style-type: none"> <li>• If the metadata content contains the <b>unsigned</b> parameter and its value is <b>true</b>, the obtained content does not have the signature information.</li> <li>• If the metadata content does not contain the <b>unsigned</b> parameter or its value is not <b>true</b>, the obtained content contains the signature information, and so the signature verification can be performed.</li> </ul> <p><b>NOTE</b><br/>When logging in to the address, the content of the <b>metadata</b> file is displayed. Press <b>ctrl+s</b> to save the content.</p> |
| CBC request address                              | Indicates the path (endpoint) provided by CBC to access the partner operation capability.<br><br>The partner adds the address and the URI of a specific API to access the API.  | <a href="https://bss.myhuaweicloud.eu">https://bss.myhuaweicloud.eu</a>  |
| Partner Center                                   | Indicates the operation management UI provided by HUAWEI CLOUD for the partner.   | <a href="https://account.eu.huaweicloud.com/obmgr/#/obmgr/index">https://account.eu.huaweicloud.com/obmgr/#/obmgr/index</a>  |

| Environment    | Description  | Address   |
|----------------|--|---|
| My Account     | Common customers (not partners) can view with basic account information, perform user authentication, configure preferences, and view their privileges and recommended operation management pages.   | <a href="https://account.eu.huaweicloud.com/usercenter/#/accountindex/accountInfo">https://account.eu.huaweicloud.com/usercenter/#/accountindex/accountInfo</a> |
| Billing Center | HUAWEI CLOUD provides the operation management UI for common customers not partners to recharge, renew, view orders, view financial information, view vouchers and discounts, apply for contracts, issue invoices, and perform unsubscription and changes. | <a href="https://account.eu.huaweicloud.com/usercenter">https://account.eu.huaweicloud.com/usercenter</a>   |
| Console        | Common customers (not partners) can log in to the HUAWEI CLOUD management console to view, purchase, and use HUAWEI CLOUD services.  | <a href="https://console.eu.huaweicloud.com/console/">https://console.eu.huaweicloud.com/console/</a>   |