

CloudTable Service

Best Practice

Issue **03**
Date **2019-07-03**

Copyright © Huawei Technologies Co., Ltd. 2020. All rights reserved.

No part of this document may be reproduced or transmitted in any form or by any means without prior written consent of Huawei Technologies Co., Ltd.

Trademarks and Permissions



HUAWEI and other Huawei trademarks are trademarks of Huawei Technologies Co., Ltd.

All other trademarks and trade names mentioned in this document are the property of their respective holders.

Notice

The purchased products, services and features are stipulated by the contract made between Huawei and the customer. All or part of the products, services and features described in this document may not be within the purchase scope or the usage scope. Unless otherwise specified in the contract, all statements, information, and recommendations in this document are provided "AS IS" without warranties, guarantees or representations of any kind, either express or implied.

The information in this document is subject to change without notice. Every effort has been made in the preparation of this document to ensure accuracy of the contents, but all statements, information, and recommendations in this document do not constitute a warranty of any kind, express or implied.

Huawei Technologies Co., Ltd.

Address: Huawei Industrial Base
Bantian, Longgang
Shenzhen 518129
People's Republic of China

Website: <https://www.huawei.com>

Email: support@huawei.com

Contents

1 Using CloudTable to Detect Boiler Abnormalities in Real Time	1
---	----------

1 Using CloudTable to Detect Boiler Abnormalities in Real Time

This document is written based on the practices of CloudTable Service (CloudTable for short) on HUAWEI CLOUD and provides guidance for you to use CloudTable to implement real-time IoT data storage and analysis.

The document contains the following parts:

- [Scenario](#)
- [Step 1: Purchase the IoT Real-time Data Processing and Storage Package](#)
- [Step 2: Enable SMN and Subscribe to SMS Notification](#)
- [Step 3: Configure CS Job Parameters in a Package](#)
- [Step 4: Log In to the Web UI and Add a Data Source on the Grafana Page](#)
- [Step 5: Use the DIS Client to Send Data](#)
- [Step 6: View Data on the Web UI](#)
- [Step 7: Clear Resources](#)

Scenario

Description

This project uses the boiler anomaly detection of a water supply company as an example to get you familiar with real-time data ingestion, data processing, and data display. Through this project, you can understand how to use Data Ingestion Service (DIS), Cloud Stream Service (CS), and CloudTable Service (CloudTable) on HUAWEI CLOUD.

In this project, real-time data generated by water devices is simulated and uploaded to HUAWEI CLOUD. HUAWEI CLOUD services can detect the anomaly of boilers and output reports that show the running status of boilers in different dimensions, so that alarms are generated when boilers are abnormal and the running status of boilers can be observed continuously. The following figure shows a typical scenario.

Figure 1-1 Typical scenario

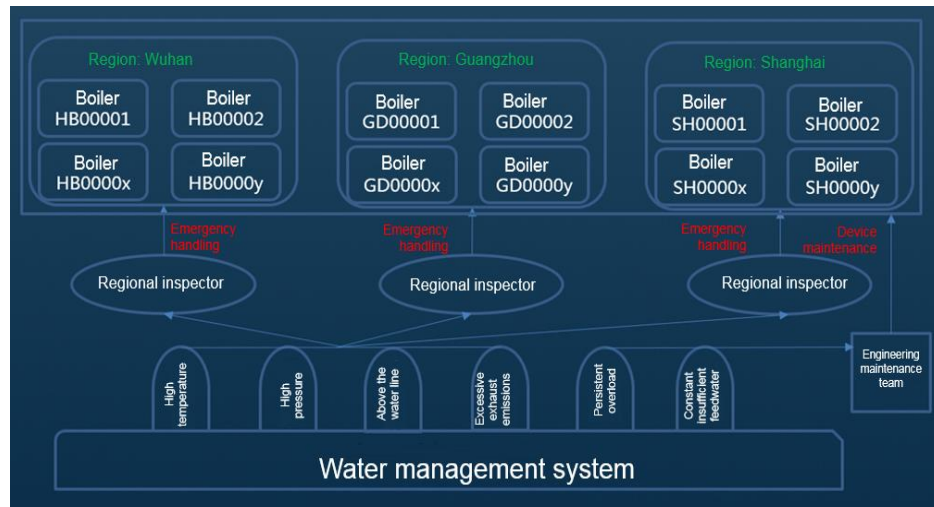

A customer expects that the running status of boilers can be detected and reported so that when the temperature, pressure, and water line of boilers exceed their thresholds, the regional inspectors can be notified for emergency handling. In addition, real-time data must be observed continuously to help the customer check the health status of boilers and decide whether the boilers need to be replaced or repaired by an engineering maintenance team.

Data Description

The following is a piece of data detected by a monitoring device.

```
{ "equId": "15", "equType": "2", "zoneId": "1", "uploadTime": 1527000545560, "runningTime": 52.0, "temperature": 66.9, "pressure": 1.31, "waterLine": 42.6, "targetTemperature": 68.0, "targetPressure": 2.07, "targetWaterLine": 38.0, "feedWater": 0.116, "noxEmissions": 50.3, "unitLoad": 83.9 }
```

The data definition and details are as follows:

Table 1-1 Data definition

Parameter	Type	Description
equId	string	Device ID
equType	string	Device type
zoneId	string	Zone ID
uploadTime	long	Upload time
runningTime	double	Running time (hour)
temperature	double	Temperature (°C)
pressure	double	Pressure (MPa)
waterLine	double	Water line (cm)
targetTemperature	double	Target temperature

Parameter	Type	Description
targetPressure	double	Target pressure
targetWaterLine	double	Target water line
feedWater	double	Feedwater (m ³ /h)
noxEmissions	double	Nox emission (mg/Nm ³)
unitLoad	double	Unit load (%)

Solution

Solution architecture: Device running data is acquired by the boiler monitoring device and uploaded to HUAWEI CLOUD using DIS. Data is processed based on the rules configured by CS. If an exception occurs, an alarm is triggered and sent to you in SMS using the Simple Message Notification (SMN) service. At the same time, the data is inputted into CloudTable (OpenTSDB), and Grafana continuously monitors the running data of the devices to check the health status.

Figure 1-2 Solution architecture

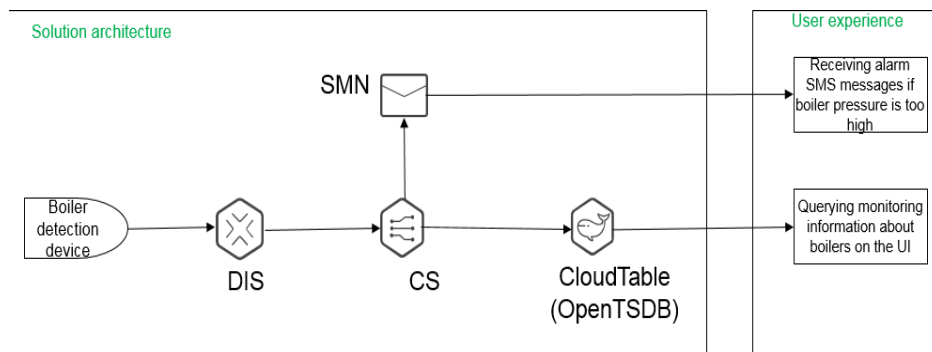

The following cloud services are involved:

- **DIS:** DIS uploads data from the detection device to the cloud and imports the data to CS in real time.
- **CS:** CS configures data processing rules and triggers SMN to send alarm messages when exceptions occur.
- **CloudTable:** CloudTable provides OpenTSDB and is interconnected with Grafana to observe the running status of devices in real time, thus checking their health status.
- **SMN:** When the SMS notification is subscribed on SMN, your mobile phone can receive SMS messages if an alarm is triggered. For example, you can receive an SMS message for notifying you of high pressure of boilers.
- **ECS:** Indicates Elastic Cloud Server. The ECS is preinstalled with the DemoUI that can demonstrate EI real-time data. You can use images to quickly interconnect with your production environment to enable the data display function. For example, in this scenario, the customer can query the boiler monitoring information on the web UI.
- **DLF:** Indicates Data Lake Factory. On the **Dashboard** of DLF, purchase the **IoT Real-time Data Processing and Storage** package so that you can enable and configure

DIS, CS, CloudTable, and DemoUI in one click to deploy an application that can quickly process IoT real-time streams.

Tasks

1. Your mobile phone can receive alarm messages.
2. You can view the running status of devices on Grafana.

Step 1: Purchase the IoT Real-time Data Processing and Storage Package

On the **Dashboard** of DLF, purchase the **IoT Real-time Data Processing and Storage** package so that you can enable and configure DIS, CS, CloudTable, and DemoUI in one click to deploy an application that can quickly process IoT real-time streams.

- Step 1** Log in to the [public cloud management console](#), click  in the upper left corner, and choose **CN North-Beijing1**.

Figure 1-3 Selecting a region

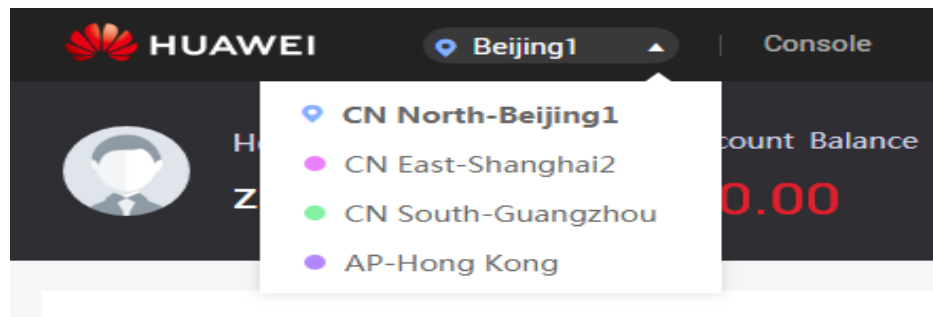

- Step 2** Create a VPC.

Virtual Private Cloud (VPC) creates an isolated virtual network that can be configured and managed by users as required for cloud services, improving resource security and simplifying network deployment.

Before purchasing the package, perform the following steps to create a VPC:

1. In the top navigation bar on the management console, click **Service List** and choose **Network > Virtual Private Cloud**. The VPC service page is displayed.
2. On the service page of VPC, click **Create VPC** in the upper right corner.

Figure 1-4 VPC page

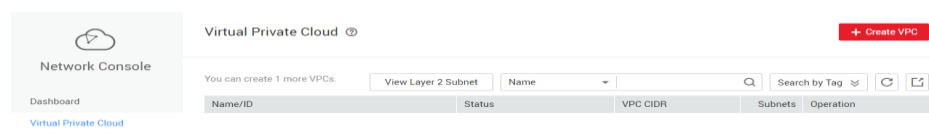

3. On the **Create VPC** page, set the following parameters and click **Create Now**.
 - **Region:** CN North-Beijing1
 - **Name:** vpc-demo (You can specify a name according to the naming rule.)

- **CIDR Block:** Retain the default value.
- **Tag:** This field is left blank by default.
- **AZ:** AZ2
- **Name:** subnet-demo (You can specify a name according to the naming rule.)
- **CIDR Block:** Retain the default value.
- **Advanced Settings:** Select **Default**.

Figure 1-5 Creating a VPC

The screenshot shows the 'Create VPC' configuration page. Under 'Basic Information', the Region is 'CN North-Beijing1', Name is 'vpc-demo', and CIDR Block is '192.168.0.0/16'. Under 'Subnet Settings', the Default Subnet is 'AZ2', Name is 'subnet-demo', and CIDR Block is '192.168.0.0/24'. The 'Advanced Settings' are set to 'Default'.

4. Back to the VPC list and view the newly created VPC.

Figure 1-6 Viewing the VPC

ID	Name	Status	VPC CIDR	Subnets	Operation
vpc-4p010	vpc-demo	Normal	192.168.0.0/16	1	Modify Delete

Step 3 If you use CS for the first time, you need to enable CS first. For details, see [Enabling CS](#).

If you have enabled CS before, skip this step.

Step 4 In the top navigation bar on the management console, click **Service List**, and choose **EI Enterprise Intelligence > Data Lake Factory**. The DLF management console is displayed.

Step 5 In the **IoT Real-Time Data Processing and Storage** area, click **Purchase Package**.

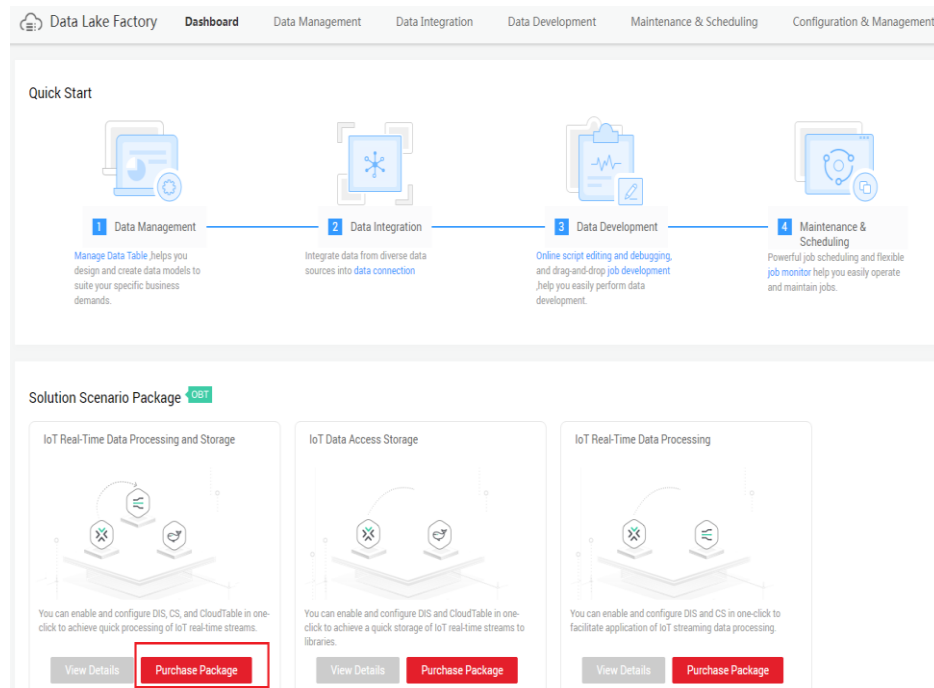
Figure 1-7 Purchasing the package**Step 6** On the purchase page, set the following parameters:

- **Name:** Enter a name according to the actual requirements, for example, **IoT-0109**. This package includes DIS, CS, CloudTable, and ECSs preinstalled with DemoUI, all of which are named by the **name** you enter.
- **AZ:** Retain the default value.
- **Partitions:** Retain the default value.
- **SPU Quota:** Retain the default value.
- **RS Units:** Retain the default value.
- **TSD Units:** Retain the default value.
- **Advanced Feature:** Select this option of CloudTable.
- **VPC and Subnet:** Select the VPC and subnet created in [Step 1: Purchase the IoT Real-time Data Processing and Storage Package](#), accordingly.
- **Security Group:** Select the default security group **Sys-default**.
- **Application Name:** Select **DemoUI**. After you purchase DemoUI, the ECS and the EIP are automatically included. The username and password for logging in to the ECS are **root** and **test@1234**, respectively. Ensure that ports 8080 and 3000 of the security group are open.
- **Sample Name:** Select **[IoT]Boiler exception detection**.
- **Select SMN Topic:** Select the topic created in [Step 2: Enable SMN and Subscribe to SMS Notification](#).

Figure 1-8 Purchasing an IoT solution

The screenshot shows the configuration page for purchasing an IoT solution. It is divided into several sections:

- Region:** A blue button labeled "Beijing 1" with a tooltip: "To select a different region, use the region selector at the upper left of the main menu bar."
- Name:** A text input field containing "IoT-0109" with a tooltip: "The package name is self-definable."
- AZ:** A blue button labeled "AZ2".
- DIS:** A section for Data Ingestion Service. It includes a "Partitions" control with a minus sign, the number "1", and a plus sign. A tooltip states: "You have selected: Common DIS stream | 1 partition | maximum stream capacity: 1 MB/s (write) or 1000 records/s (write); 2 MB/s (read)".
- CS:** A section for CloudTable Service. It includes "SPUs" set to "6" and "SPU Quota" set to "12".
- CloudTable:** A section for advanced features. It includes:
 - "Advanced Feature" with a checked checkbox for "OpenTSDB 2.3.0".
 - "RS Units" control with a minus sign, "4", and a plus sign.
 - "TSD Units" control with a minus sign, "2", and a plus sign.
 - "VPC" dropdown menu set to "vpc-demo" with a "View VPC" link.
 - "Subnet" dropdown menu set to "subnet-demo" with a refresh icon.
 - "Security Group" dropdown menu set to "Sys-default" with a "View Security Group" link.

Figure 1-9 Template installation

The screenshot shows the configuration page for purchasing a template installation. It includes:

- Purchase Application:** "Application Name" is set to "DemoUI" with a checked checkbox. A tooltip explains: "DemoUI is a HUAWEI CLOUD EI product used to demonstrate the processing result of real-time data. With the web project and multiple open-source UI products preinstalled, DemoUI enables quick interconnection with a real-world environment through a mirror and displays data on the UI." A note below states: "After you purchase DemoUI, ECS and EIP are automatically purchased together with DemoUI. The user name and password for logging in to ECS are root and test@1234 respectively. Ensure that ports 8080 and 3000 of the security group are open."
- Template Sample:** "Sample Name" is a dropdown menu set to "[IoT] Boiler exception detection" with a tooltip: "After you select a template sample, a DIS dump sample will be automatically created." "Select SMN Topic" is a dropdown menu set to "boiler-alarm" with a tooltip: "SMN required for the topic may incur charges. For details, click View Pricing Rule."

Step 7 Click **Buy Now**. Then the order details page is displayed. Select "**I have read and agree to the Disclaimer**", and click **Submit**.

Figure 1-10 Confirming the order

Purchase the IoT Real-Time Data Processing and Storage Package [Back to IoT Real-Time Data Processing and Storage Package](#)

1 Configure 2 Confirm 3 Finish

Order Details

Service Name	Specifications	Billing Mode	Quantity	Price
	Common stream partition	On-demand	1	¥0.10/Hour
DIS	Name IoT-0109 Partitions 1 Region Beijing1	On-demand	1	Charge by usage
CS	SPU Quota 12	On-demand	6	¥3.00/Hour
	RS Units 4 TSD Units 2	On-demand	6	¥9.18/Hour
CloudTable	Name IoT-0109 Region Beijing1 AZ AZ2 VPC vpc-demo Subnet subnet-demo Security Group Sys-default Advanced Feature OpenTSDB	On-demand	1	Charge by usage
ECS	ECS Name IoT-0109	On-demand	1	¥0.41/Hour
EIP Traffic	Billing Mode Bandwidth: 5 Mbit/s	On-demand	1	Charge by usage

Configuration fee: CNY12.69/ hour
Charge by usage : DIS: CNY0.1/million payload units [View Details](#) + CloudTable: CNY0.0021/GB/hour [View Details](#)
undefined

I have read and agree to the [Disclaimer](#)

Step 8 Click **Homepage**, and view the package purchase information. It takes some time to purchase the package. Please wait patiently. After you purchase the package, **Created successfully** is displayed in the package area.

Figure 1-11 Successful creation

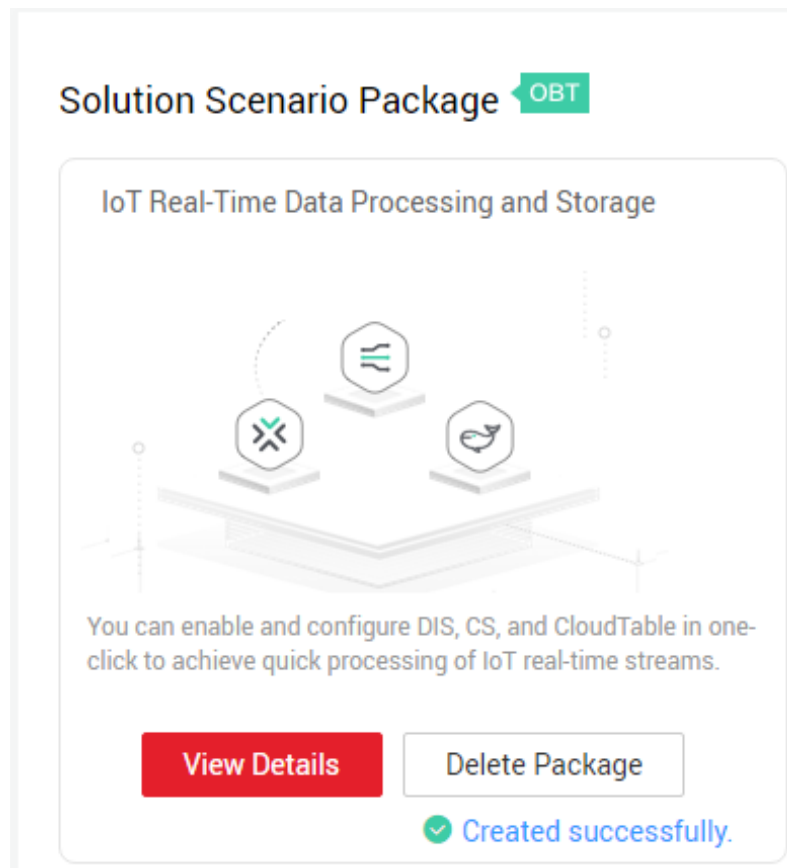

----End

Step 2: Enable SMN and Subscribe to SMS Notification

Enable SMN and subscribe to SMS notifications so that your mobile phones can receive SMS messages if a device alarm is triggered. Enable SMN by performing the following steps:

- Step 1** Log in to the [public cloud management console](#). In the top navigation bar, click **Service List**, and then select **Simple Message Notification** under **Application**.
- Step 2** Click  in the upper left corner, and select **CN North-Beijing1**.
- Step 3** In the left navigation pane, choose **Topic Management > Topics**, and then click **Create Topic** in the upper right corner.

Figure 1-12 Topic management



In the displayed **Create Topic** dialog box, enter a topic name, for example, **boiler-alarm**, and click **OK**. After the topic is created, back to the topic list.

Figure 1-13 Creating a topic

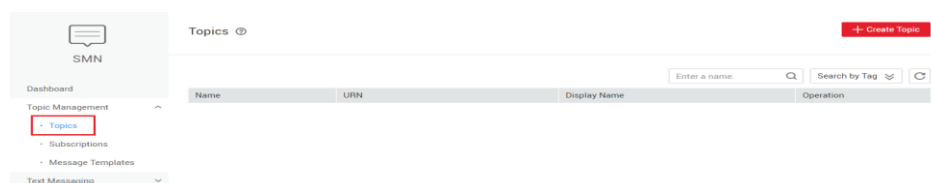
Step 4 View the newly created topic in the topic list, and choose **More > Add Subscription** in the row where the topic resides to add topic subscriptions.

Figure 1-14 Topic subscription

Name	URN	Display Name	Operation
boiler-alarm	urn:amn:cn:north-1-86b00d6f08794a968a434d7...		Publish Message More > Add Subscription Modify Display Name Configure Topic Policy Delete

In the displayed dialog box, select **SMS** for **Protocol**, and enter your mobile phone number in the **Endpoint** text box, for example, 15999*****6. Then click **OK**.

NOTE

Ensure that the registered mobile number can receive SMS messages, and you need to confirm the subscription as SMS prompted.

Figure 1-15 Adding subscriptions

Add Subscription ×

Topic Name boiler-alarm

Protocol SMS

Endpoint ⓘ 15999*****6

OK Cancel

Step 5 Request your mobile phone to accept subscriptions.

In the left navigation pane, choose **Topic Management > Subscriptions**. In the **Endpoint** area, locate the newly added subscription in the subscription list, and click **Request Confirmation** in the row where the subscription resides.

Figure 1-16 Request confirmation

Subscriptions ⓘ + Add Subscription

Request Confirmation Delete All protocols All statuses Enter an endpoint 🔍 ↻

Subscription URN	Protocol	Endpoint	Topic Name	Status	Operation
urn:smn:cn-north-1-8bb00d6f08794a9...	SMS	13588127045	boiler-alarm	Unconfirmed	Request Confirmation Delete

Click **OK** in the displayed dialog box.

Figure 1-17 Request confirmation

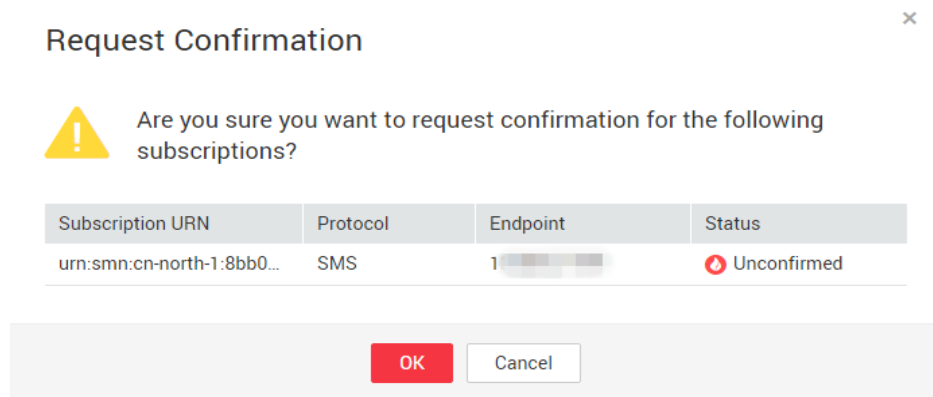

Step 6 Confirm the subscription.

After your mobile phone receives the subscription confirmation message, click the link in the message to confirm the subscription. After confirmation, click  to refresh the subscription status on the SMN subscription page. You can view that the status is changed to **Confirmed**.

Figure 1-18 Viewing the subscription status



Step 7 On the **Topics** page, locate the topic named **boiler-alarm** and record its topic URN.

Example: **urn:smn:cn-north-1:fa9ec10d1fcc476f9b33a2c98002fd8c:boiler-alarm**

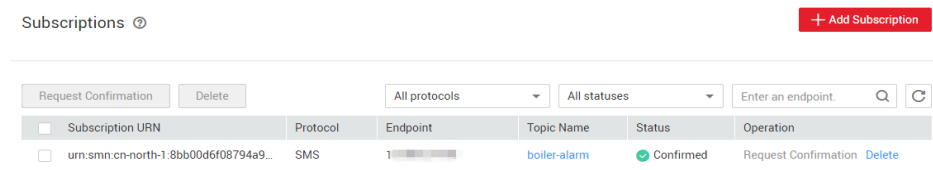
Figure 1-19 Obtaining the topic URN

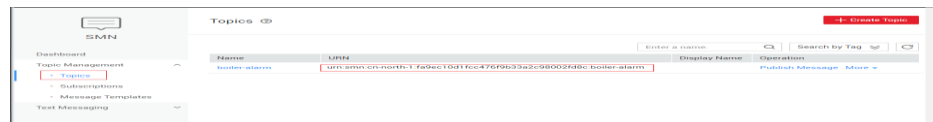

---End

Step 3: Configure CS Job Parameters in a Package

A streaming job is automatically created in CS based on the predefined template. The job is named in the **boiler-*<package name>*** format, for example, **boiler-IoT-0109**. This job is used to detect the anomaly of boilers in real time. You need to edit the job and set the parameters of the job according to actual conditions.

- Step 1** In the top navigation bar on the management console, click **Service List**, and choose **EI Enterprise Intelligence > Data Lake Factory**. The DLF management console is displayed.
- Step 2** On the **Dashboard** page, click **View Details** in the area of **IoT Real-Time Data Processing and Storage**. The job development page is displayed.

Figure 1-20 IoT package

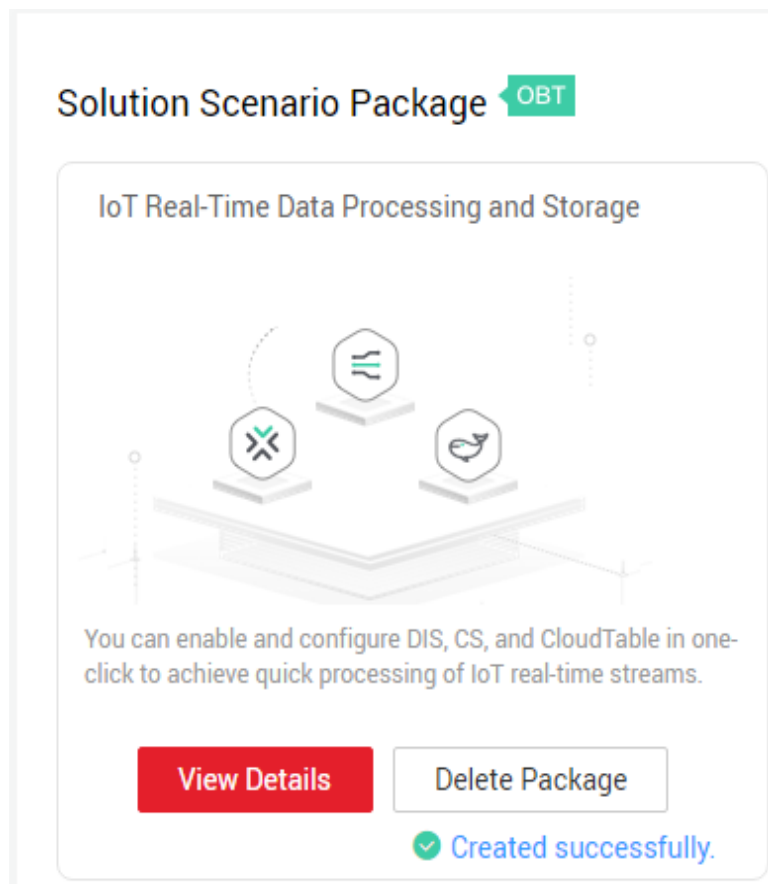

- Step 3** On the job development page, click the CloudStream operator. On the **Properties** page on the right, choose **Select an existing CS job**, and select **boiler-IoT-0109** from the **Streaming Job Name** drop-down list. Click **Save** on the upper part of the page.

Figure 1-21 Job development page

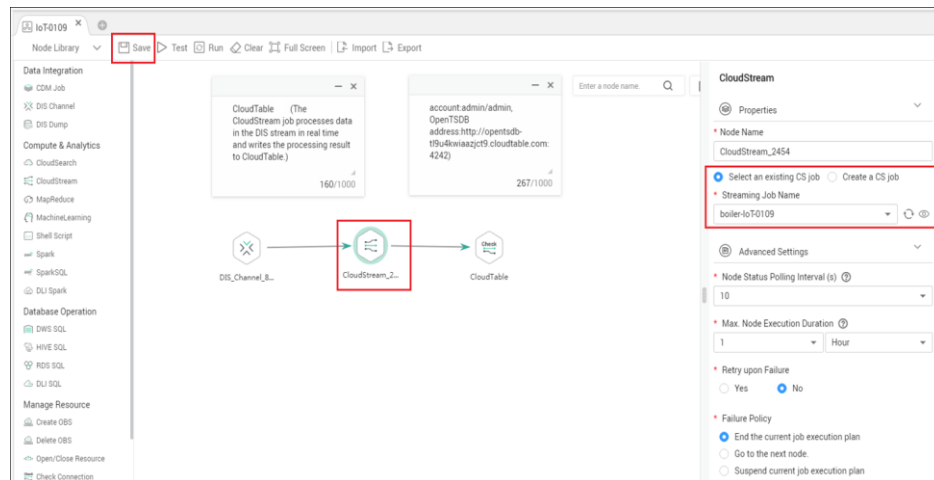

Step 4 On the **Properties** page, click  next to the **Streaming Job Name** drop-down list. The job management page is displayed.

Figure 1-22 Viewing the job



Step 5 On the **Job Management** page, select **boiler-IoT-0109** and click **Stop**. In the confirmation dialog box, click **OK**. After the job is stopped, click **Edit** in the row where **boiler-IoT-0109** is located.

Figure 1-23 Stopping the job

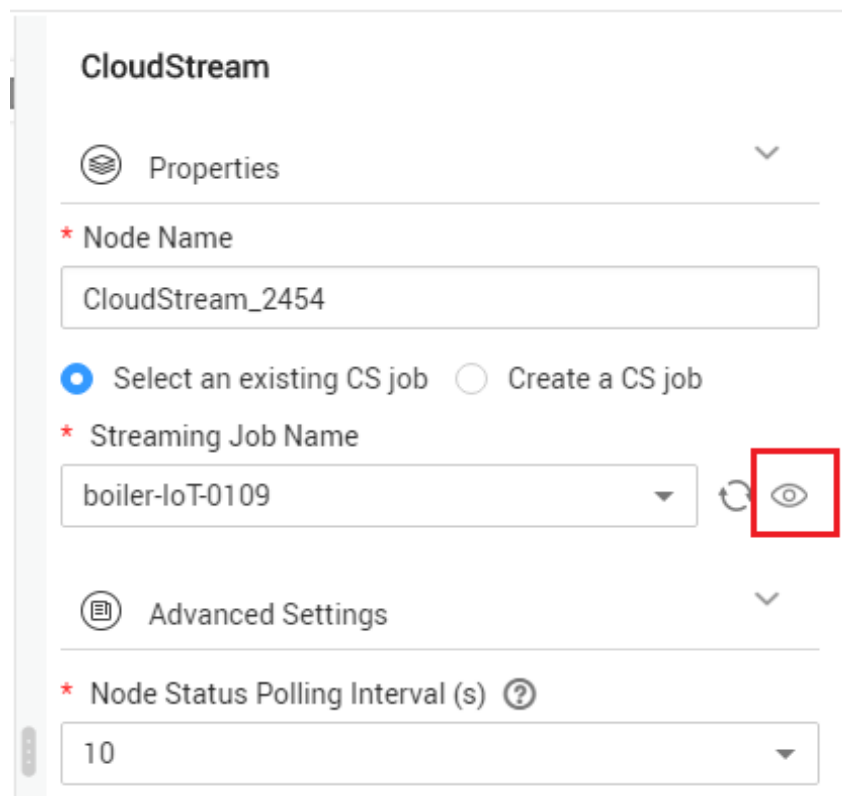
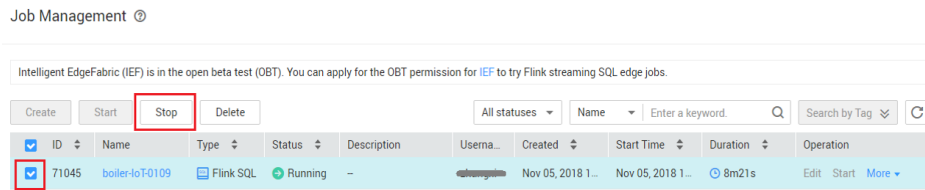

Step 6 On the job editing page, edit the job based on actual conditions.

Figure 1-24 Editing the job

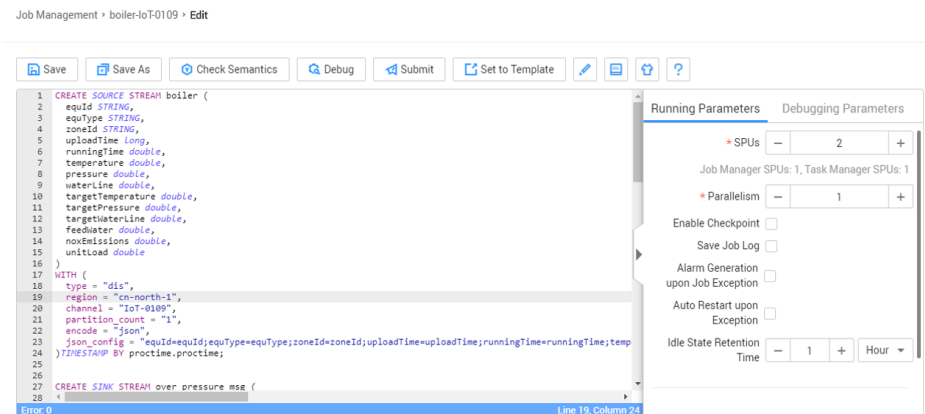

The following job script is displayed in the job editing window. The italic parameters need to be configured according to actual conditions. For more parameter information, see the parameter description below the job script.

```

CREATE SOURCE STREAM boiler (
  equId STRING,
  equType STRING,
  zoneId STRING,
  uploadTime long,
  runningTime double,
  temperature double,
  pressure double,
  waterLine double,
  targetTemperature double,
  targetPressure double,
  targetWaterLine double,
  feedWater double,
  noxEmissions double,
  unitLoad double
)
WITH (
  type = "dis",
  region = "cn-north-1",/*Indicates region information.*/
  channel = "IoT-0109",/*Indicates the name of the created DIS stream.*/
  partition count = "1",
  encode = "json",

```

```
json config =
"equId=equId;equType=equType;zoneId=zoneId;uploadTime=uploadTime;runningTime=runni
ngTime;temperature=temperature;pressure=pressure;waterLine=waterLine;targetTempera
ture=targetTemperature;targetPressure=targetPressure;targetWaterLine=targetWaterLi
ne;feedWater=feedWater;noxEmissions=noxEmissions;unitLoad=unitLoad;"
)TIMESTAMP BY proctime.proctime;

CREATE SINK STREAM over pressure msg (
  equId STRING,
  equType STRING,
  zoneId STRING,
  pressure double,
  targetPressure double,
  subject STRING
)
WITH (
  type = "smn",
  region = "cn-north-1",/*Indicates region information.*/
  topic_urn =
"urn:smn:cn-north-1:fa9ec10d1fcc476f9b33a2c98002fd8c:boiler-alarm",/*Indicates the
topic URN created using SMN.*/
  message subject = "Boiler-Alarm",
  message column = "subject"
);

/** Creates the output stream and outputs results to CloudTable.
 *
 * Modify the following options based on actual conditions (For configuration items
that support dynamic column names, the dynamic column names are represented by ${Column
name}. If multiple data points need to be inserted, separate them with semicolons (;).
 * cluster id: ID of the cluster to which the data table to be inserted belongs
 * tsdb metrics: Metric of a data point. Metrics can be optionally dynamic.
 * tsdb timestamps: Timestamp of a data point. Only dynamic columns are supported.
 * tsdb values: Value of a data point. The value can be a dynamic column or a constant
value.
 * tsdb tags: Tag of a data point. Each tag contains at least one and at most eight
values. Tags can be optionally dynamic.
 * batch insert data num: Amount of data to be written in batches at a time. The value
must be a positive integer. The upper limit is 100. The default value is 8.
 */
CREATE SINK STREAM boiler tsdb (
  equId STRING,
  equType STRING,
  zoneId STRING,
  uploadTime long,
  runningTime double,
  temperature double,
  pressure double,
  waterLine double,
  targetTemperature double,
  targetPressure double,
  targetWaterLine double,
  feedWater double,
  noxEmissions double,
```

```
        unitLoad double
    )
WITH (
    type = "opentsdb",
    region = "cn-north-1", /*Indicates region information.*/
    cluster_id = "2ada63e3-b237-45e0-8d89-4d108a6a2e9f", /*Indicates the ID of the cluster
created using CloudTable.*/
    tsdb metrics =
"runningTime;temperature;pressure;waterLine;targetTemperature;targetPressure;targe
tWaterLine;feedWater;noxEmissions;unitLoad",
    tsdb timestamps = "${uploadTime}",
    tsdb values =
"${runningTime};${temperature};${pressure};${waterLine};${targetTemperature};${tar
getPressure};${targetWaterLine};${feedWater};${noxEmissions};${unitLoad}",
    tsdb tags = "equType:${equType},zoneId:${zoneId},equId:${equId}",
    batch insert data num = "100"
);

/**Outputs some fields.**/
INSERT INTO over pressure msg
SELECT equId,equType,zoneId,pressure,targetPressure,"EquId "||equId||"
targetPressure is "||CAST(targetPressure as VARCHAR(8))||", but now pressure is
"||CAST(pressure as VARCHAR(8))||", please check it quickly."
FROM
(SELECT equId, equType, zoneId, targetPressure, MAX(pressure) as pressure,
count(pressure) as cnt1 FROM boiler WHERE pressure > targetPressure GROUP BY
TUMBLE(proctime, INTERVAL '30' SECOND), equId, equType, zoneId, targetPressure) WHERE
cnt1 >= 4;

/**Outputs the information.**/
INSERT INTO boiler tsdb
SELECT
    equId,
    equType,
    zoneId,
    uploadTime,
    runningTime,
    temperature,
    pressure,
    waterLine,
    targetTemperature,
    targetPressure,
    targetWaterLine,
    feedWater,
    noxEmissions,
    unitLoad
FROM boiler;
```

The parameters are described as follows:

- **region**: Set this parameter to the region you select when purchasing the package. For example, set it to **cn-north-1**, which represents the **CN North-Beijing1** region. For more information about regions, see [Regions and Endpoints](#).

- **Channel:** name of the DIS stream. After a package is purchased, a DIS stream named after the package name is automatically created. In this example, the DIS stream name is **IoT-0109**.
- **topic_urn:** Set this parameter to the URN created in [Step 2: Enable SMN and Subscribe to SMS Notification](#).
- **cluster-id:** cluster ID of CloudTable

Log in to the CloudTable management console. In the left navigation pane, choose **Cluster Mode**. In the cluster list, locate the desired cluster and click the cluster name. On the cluster details page that is displayed, obtain the CloudTable cluster ID. See the following figure.

Figure 1-25 Cluster information

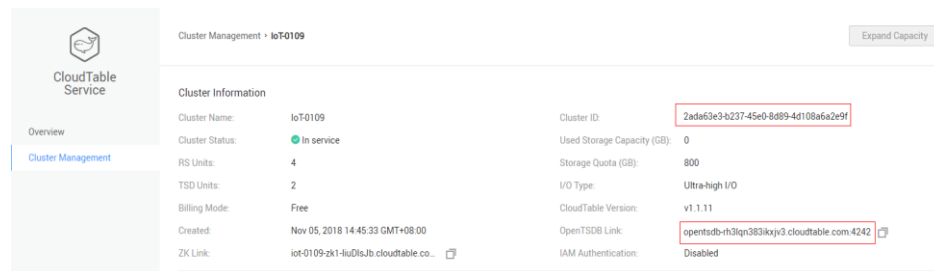

Step 7 Click **Check Semantics**. If the check is successful, click **Save**.

Figure 1-26 Editing the job

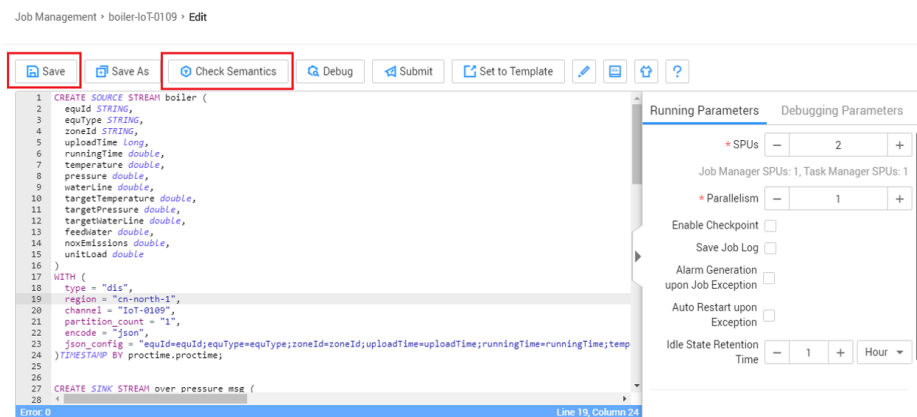

NOTE

The following statement in the job is used to control the threshold for the anomaly detection of boilers. Alarms will be generated when the pressure exceeds the **targetPressure** value for four times within 30 seconds.

```
SELECT equId,equType,zoneId,pressure,targetPressure,"EquId |||equId|||"  
targetPressure is "||CAST(targetPressure as VARCHAR(8))||", but now pressure is  
"||CAST(pressure as VARCHAR(8))||", please check it quickly."  
FROM  
(SELECT equId, equType, zoneId, targetPressure, MAX(pressure) as pressure,  
count(pressure) as cnt1 FROM boiler WHERE pressure > targetPressure GROUP BY
```

```
TUMBLE(proctime, INTERVAL '30' SECOND), equId, equType, zoneId, targetPressure)
WHERE cnt1 >= 4;
```

Step 8 Click **Submit**. In the confirmation dialog box that is displayed, click **OK**.

----End

Step 4: Log In to the Web UI and Add a Data Source on the Grafana Page

Step 1 Obtain the EIP of the DemoUI.

In the top navigation bar on the management console, click **Service List**, and choose **Computing > Elastic Cloud Server**. The ECS management console is displayed. Locate the ECS named **IoT-0109** and record the EIP of this ECS.

Figure 1-27 Viewing the EIP

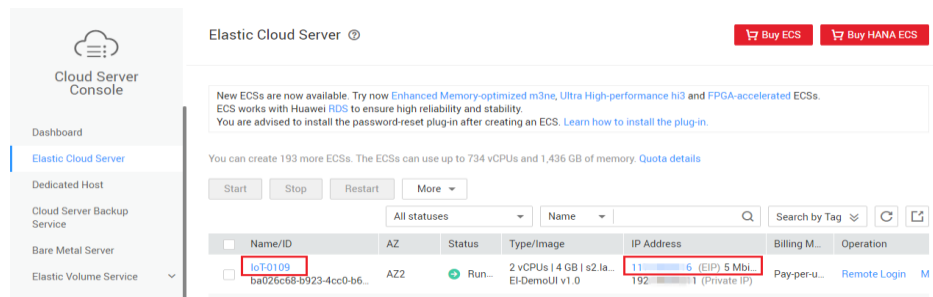

Step 2 Launch the browser and enter a URL, for example, **http://ecs.ip:3000** (**ecs.ip** indicates the EIP of ECSs obtained in [Step 1](#).) Enter the username and password to log in to the IoT service. The default username and password are **admin** and **admin**, respectively. Then the following page is displayed:

Figure 1-28 WebUI

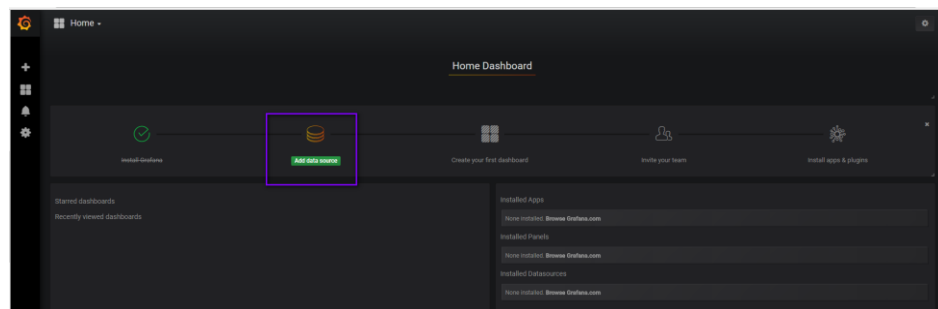

Step 3 Click **Add data source** to add a data source.

Figure 1-29 Adding a data source

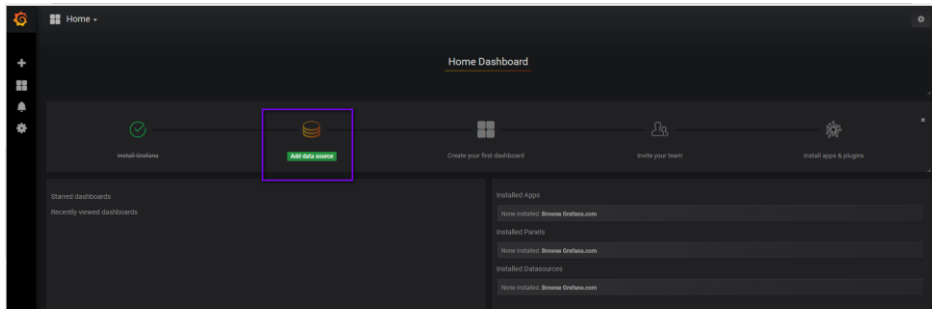

Step 4 On the configuration page of the data source, set the following parameters:

- **Name:** Enter a user-defined name.
- **Type:** Choose **OpenTSDB**.
- **URL:** Set this parameter to **http://<OpenTSDB link of the CloudTable cluster>**, for example, **http://opentsdb-rh3lqn383ikxjv3.cloudtable.com:4242**.

Log in to the CloudTable management console. In the left navigation pane, choose **Cluster Mode**. In the cluster list, locate the desired cluster and click the cluster name. On the cluster details page that is displayed, obtain the OpenTSDB link of the CloudTable cluster. See the following figure.

Figure 1-30 Cluster information

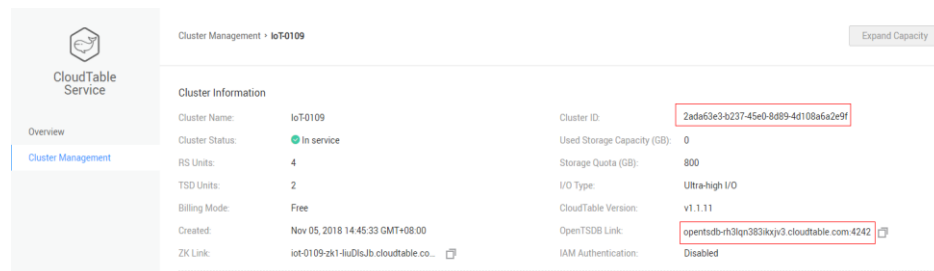

- **Version:** Select **==2.3**.

Figure 1-31 Configuring a data source

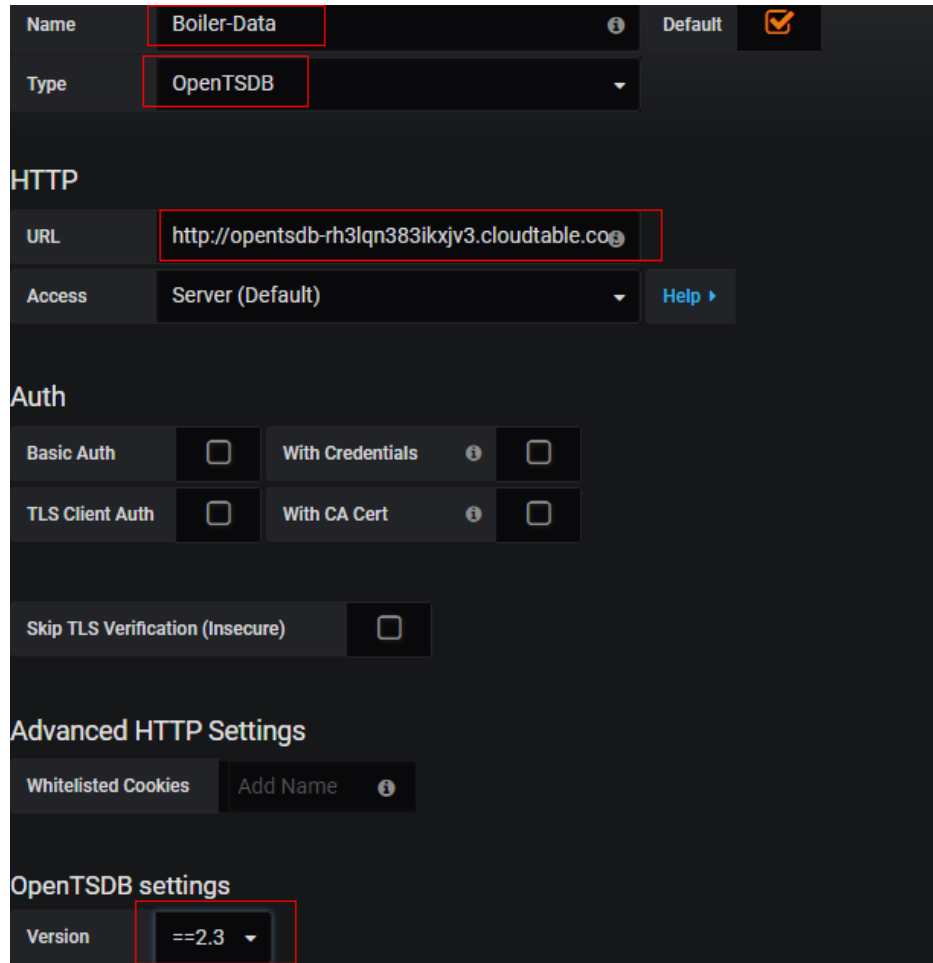

Step 5 Click **Save&Test**.

----End

Step 5: Use the DIS Client to Send Data

A DIS client has been set up on CloutTable. This client simulates boilers to generate abnormal data and uploads the data to HUAWEI CLOUD. You can download the DIS client from OBS on HUAWEI CLOUD.

Step 1 Set up a computer running the Windows operating system, log in to HUAWEI CLOUD, and access the following address to obtain the DIS client:

https://dis-publish.obs.myhwclouds.com/datasets/demo/20180529_huarui/dis-boiler-1.0.0.zip

Step 2 Configure the DIS client.

Decompress the downloaded **dis-boiler-1.0.0.zip** package to a local directory and edit the **dis.properties** file.

Figure 1-32 DIS client

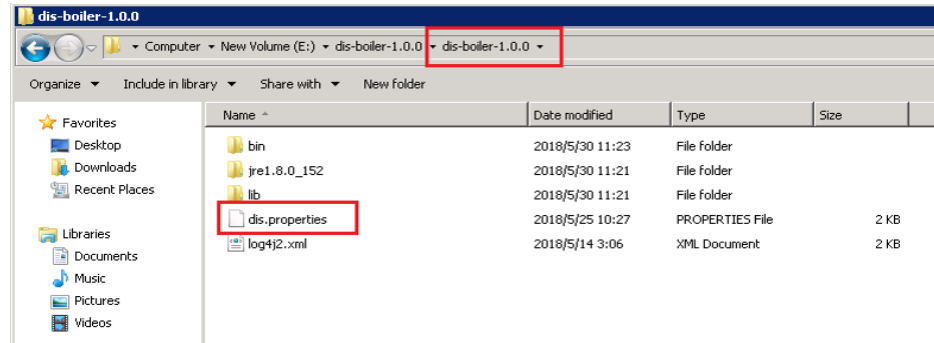

The following provides an example of the **dis.properties** configuration file. Set the **region**, **ak**, **sk**, **projectId**, **endpoint**, and **stream_name** parameters in bold based on the parameter description below.

```
region=cn-north-1
ak=UKP1SHOLFXYBWTYF7LRH
sk=pYuYeWtoJsioQHLG8DxzJsb68hNf2N2ueCGXgHpy
projectId=cbb9c2d6c9d1474f9a50f39baff62337
endpoint=https://dis.cn-north-1.myhuaweicloud.com:20004
stream_name=IoT-0109
data.timestamp=now
# Number of sent messages. (The value -1 indicates no limit.)
producer record num=-1
# Length of each message (B)
producer record length=1024
# Number of sent threads
producer thread num=1
# Number of messages contained in each request
producer request record num=200
# Sleep interval of each request (ms)
producer request sleep time=1000

# Consumption start position on Consumer (-2 indicates that consumption starts at the
earliest location; -1 indicates that consumption starts at the latest location; N (N
≥ 0) indicates that consumption starts at the specified location.)
consumer offset=-1
# Number of consumed partitions (auto: automatically obtains and consumes all partitions;
positive integer N (N>0): consumes data of only the first N partitions.)
consumer partition num=1
# Maximum number of messages that is expected to be received each time a consumption
request is sent.
consumer limit=10000
# CloudTable data input
producer record data=aaaaaa

# Number of partitions for creating the stream
create partition num=100
# Type of the created stream (COMMON indicates a common stream; ADVANCED indicates an
advanced stream.)
```

```
create stream type=ADVANCED
# Life cycle of the created stream (1 to 7)
create data duration=7
# Name of the OBS bucket for dumping the stream (If this parameter is left blank, the
stream is not dumped.)
create obs bucket name=
# Agency name for dumping the created stream to OBS
create agency name=

# Number of cycles for automatic tests (creation/uploading/details/deletion) (-1
indicates the unlimited running times; N (N>0) indicates specified running times only.)
auto run num=1
# Character string carried in the stream name during the automatic test, used to mark
the stream source.
auto_run_user_name=dis
```

The parameters are described as follows:

- **region**: Set this parameter to the region selected in [Step 1: Purchase the IoT Real-time Data Processing and Storage Package](#). For example, set it to **cn-north-1**, which represents the **CN North-Beijing1** region. For more information about regions, see [Regions and Endpoints](#).
- **ak** and **sk**: AK/SK (Access Key ID/Secret Access Key)

Log in to the HUAWEI CLOUD management console, move your cursor over your account in the upper right corner, and click **My Credential** from the drop-down list.

Figure 1-33 My credential

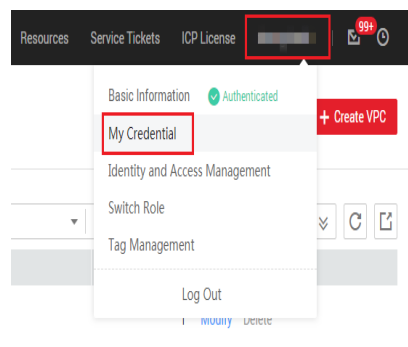

On the **My Credential** page, click **Access Keys**, and then click **Add Access Key** to generate a key file. Download and save the file. (Note that keep the key file properly.) If an access key has been created, view the key file and obtain AK/SK information.

Figure 1-34 Adding an access key

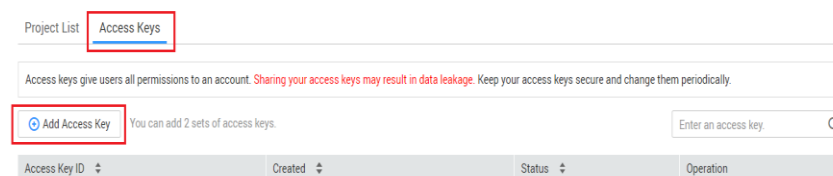

- **ProjectId**: project ID. Log in to the HUAWEI CLOUD management console, move your cursor over your account in the upper right corner, click **My Credential** from the drop-down list, and then view project IDs of different regions on the **Projects** tab page.

Figure 1-35 Obtaining a project ID

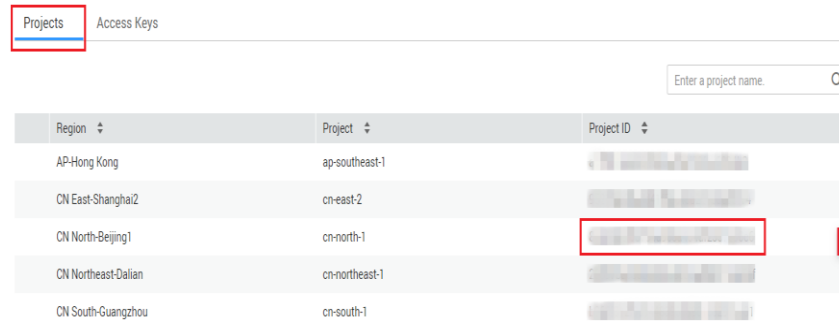

- **endpoint**: Set this parameter to **https://<DIS endpoint>**. The following provides endpoint information of DIS. For details about regions and endpoints, see [Regions and Endpoints](#).

Table 1-2 Information about regions and endpoints

Region Name	Region	Endpoint	Protocol Type
CN North-Beijing 1	cn-north-1	dis.cn-north-1.myhuaweicloud.com:20004	HTTPS
CN South-Guang zhou	cn-south-1	dis.cn-south-1.myhuaweicloud.com	HTTPS

- **stream_name**: name of the DIS stream. After [Step 1: Purchase the IoT Real-time Data Processing and Storage Package](#) has been completed successfully, a DIS stream named after the package name is automatically created. In this example, the DIS stream name is **IoT-0109**.

Step 3 Start the DIS client to send data.

On the DIS client host, go to the DIS client directory **dis-boiler-1.0.0\bin**. Double-click **start_producer.bat** to start the DIS client to send data.

Figure 1-36 Sending data

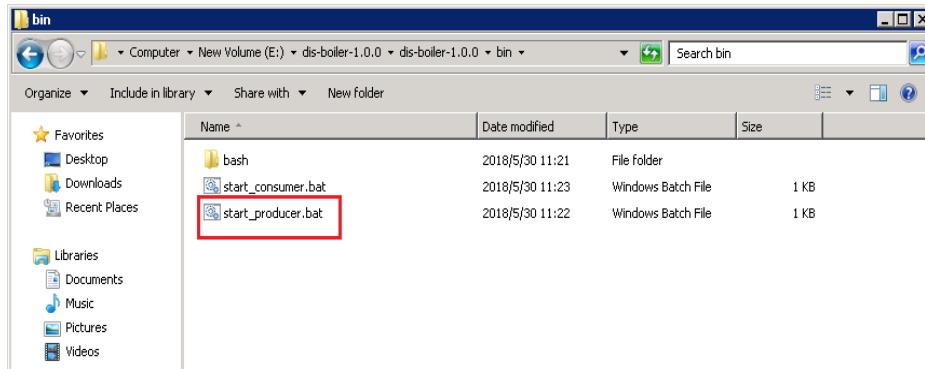

----End

Step 6: View Data on the Web UI

Viewing the Pressure of Boilers on Grafana

Step 1 Log in to the web UI. For details on the login method, see [Step 4: Log In to the Web UI and Add a Data Source on the Grafana Page.](#)

Step 2 On Grafana, click **New dashboard**.

Figure 1-37 Creating a dashboard

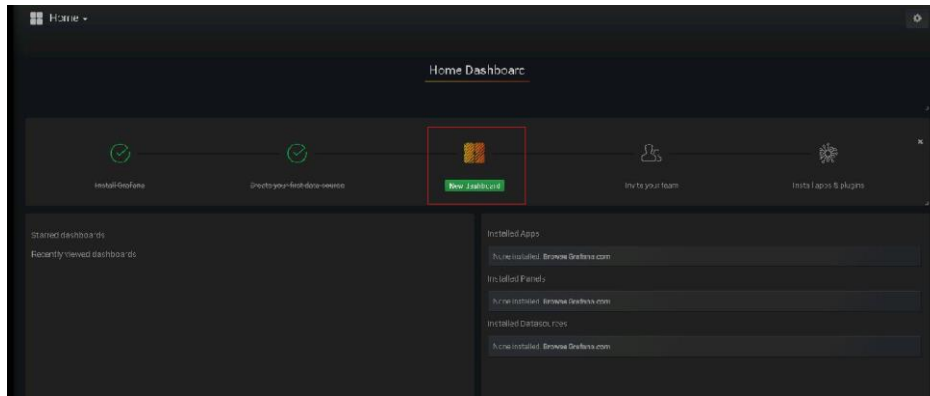

Step 3 On the **New dashboard** page, click **Graph**.

Figure 1-38 Selecting Graph

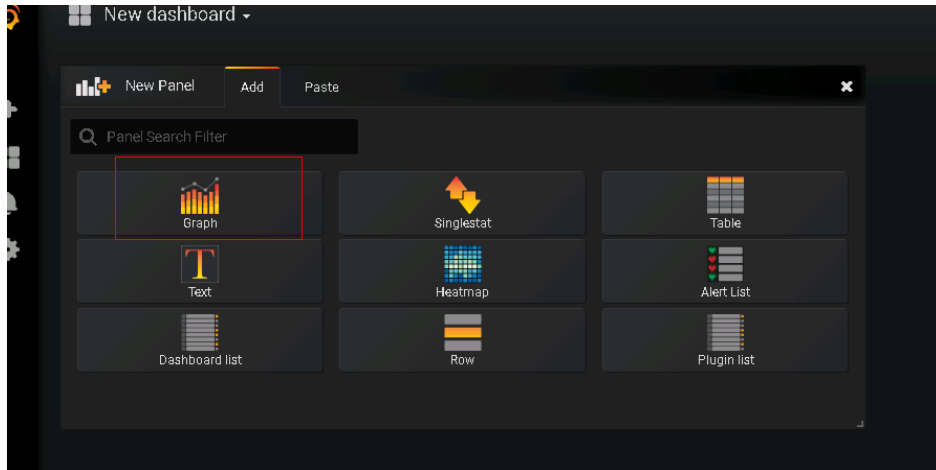

Step 4 Click **Panel Title** and then select **Edit** from the drop-down list.

Figure 1-39 Editing

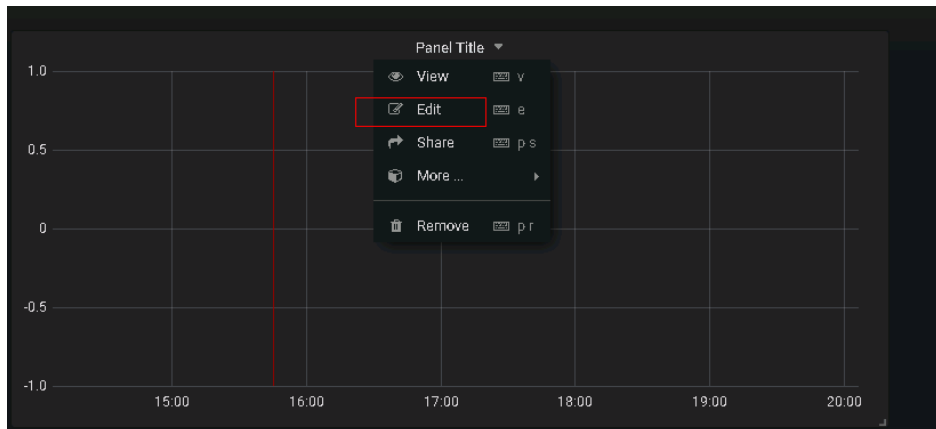

Step 5 Click the **Metric** tab, and then select **Boiler-Data** from the **Data Source** drop-down list.

Figure 1-40 Selecting a data source

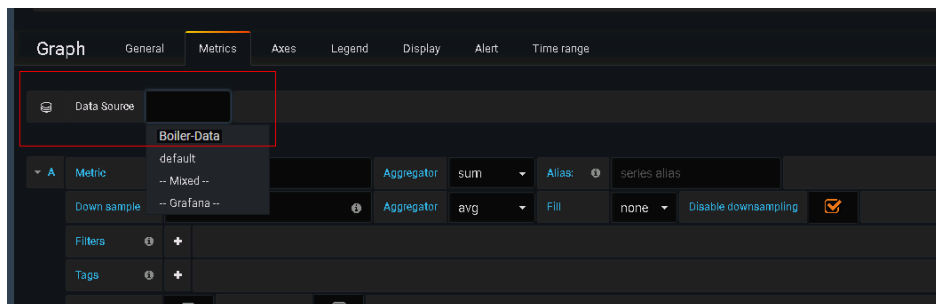

- Step 6** On the **Metric** tab page, set **Metric** to **pressure** (boiler pressure). Select **avg** from the **Aggregator** drop-down list, and then you can view the average pressure of boilers.

Figure 1-41 Viewing results

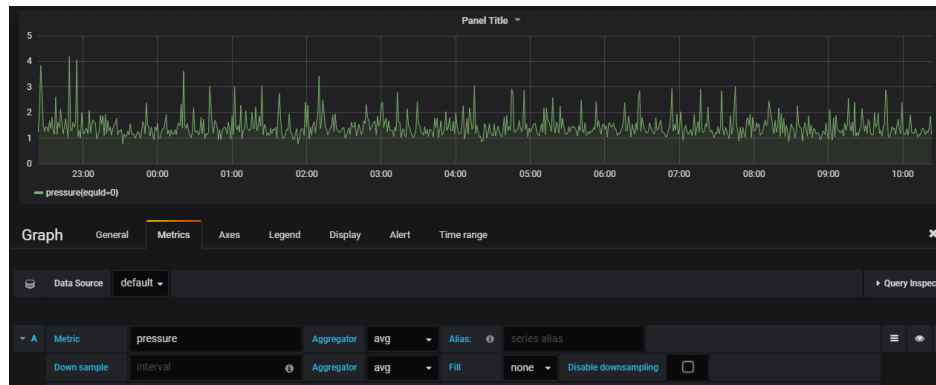

----End

Viewing Alarms on Your Mobile Phone

Your mobile phone receives the alarms about boilers. For details about alarm rules, refer to job script settings in [Step 3: Configure CS Job Parameters in a Package](#).

Step 7: Clear Resources

If you do not want to use the purchased boiler anomaly detection package, you can delete it. The deleted package cannot be recovered. Exercise caution when performing this operation.

- Step 1** Log in to the [public cloud management console](#). In the top navigation bar on the management console, click **Service List**, and choose **EI Enterprise Intelligence > Data Lake Factory**. The DLF management console is displayed.
- Step 2** Click  in the upper left corner, and select **CN North-Beijing1**.
- Step 3** In the **IoT Real-Time Data Processing and Storage** area, click **Delete Package**. In the displayed dialog box, click **OK**.

Figure 1-42 Deleting a package



Step 4 After the package is deleted, jobs in CS need to be manually deleted. Delete jobs by performing the following steps:

1. In the top navigation bar on the management console, click **Service List**, and choose **EI Enterprise Intelligence > Cloud Stream Service**. The CS management console is displayed.
2. Click **Job Management**, select **boiler-IoT-0109** from the job list, and click **Delete**.
3. In the displayed dialog box, click **OK**.

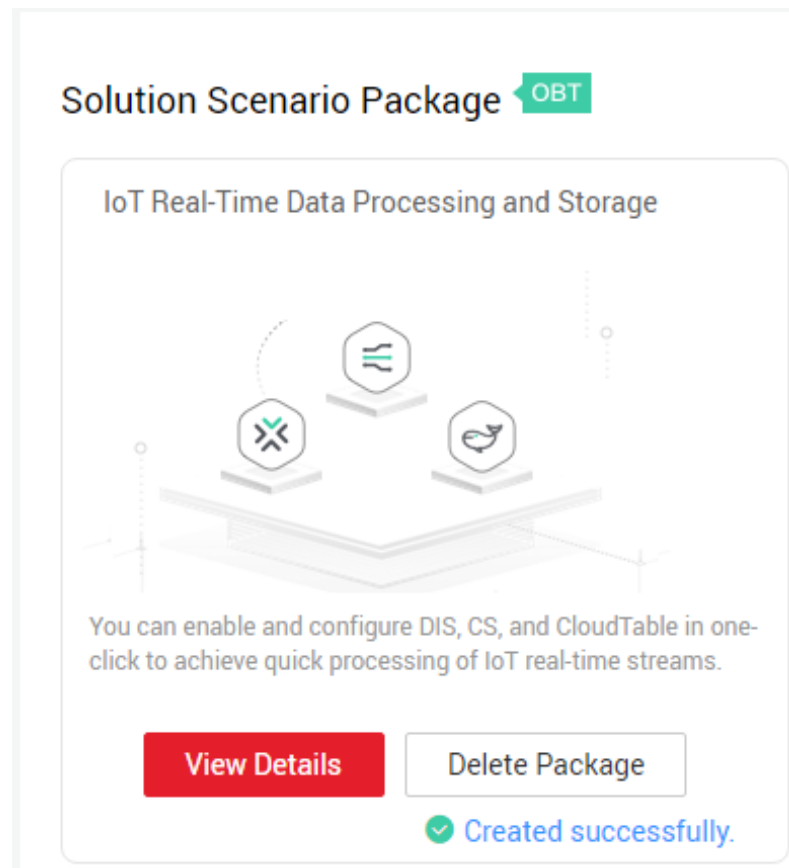
Step 5 Delete mobile phone subscription.

1. In the top navigation bar of the management console, click **Service List**, and then select **Simple Message Notification** under **Application**.
2. In the left navigation pane, choose **Topic Management > Subscriptions**. In the subscription list, locate the desired subscription URN, and click **Delete**.
3. In the left navigation pane, choose **Topic Management > Topics**. In the topic list, locate the desired topic and click **Delete**.

Step 6 Delete the VPC and subnet.

1. In the top navigation bar on the management console, click **Service List** and choose **Network > Virtual Private Cloud**. The VPC service page is displayed.
2. Delete the subnet. Before deleting the subnet, ensure that the subnet is not bound to other resources.

In the left navigation pane, choose **Virtual Private Cloud**. In the VPC list, click **vpc-demo**. On the subnet page that is displayed, locate **subnet-demo** in the subnet list and click **Delete**.

3. Delete the VPC. Before deleting the VPC, ensure that the VPC is not bound to other resources.

In the left navigation pane, choose **Virtual Private Cloud**. In the VPC list, locate **vpc-demo** in the VPC list and click **Delete**.

---End